

MEDIUM VOLTAGE CABLE

What Links Power to the World?

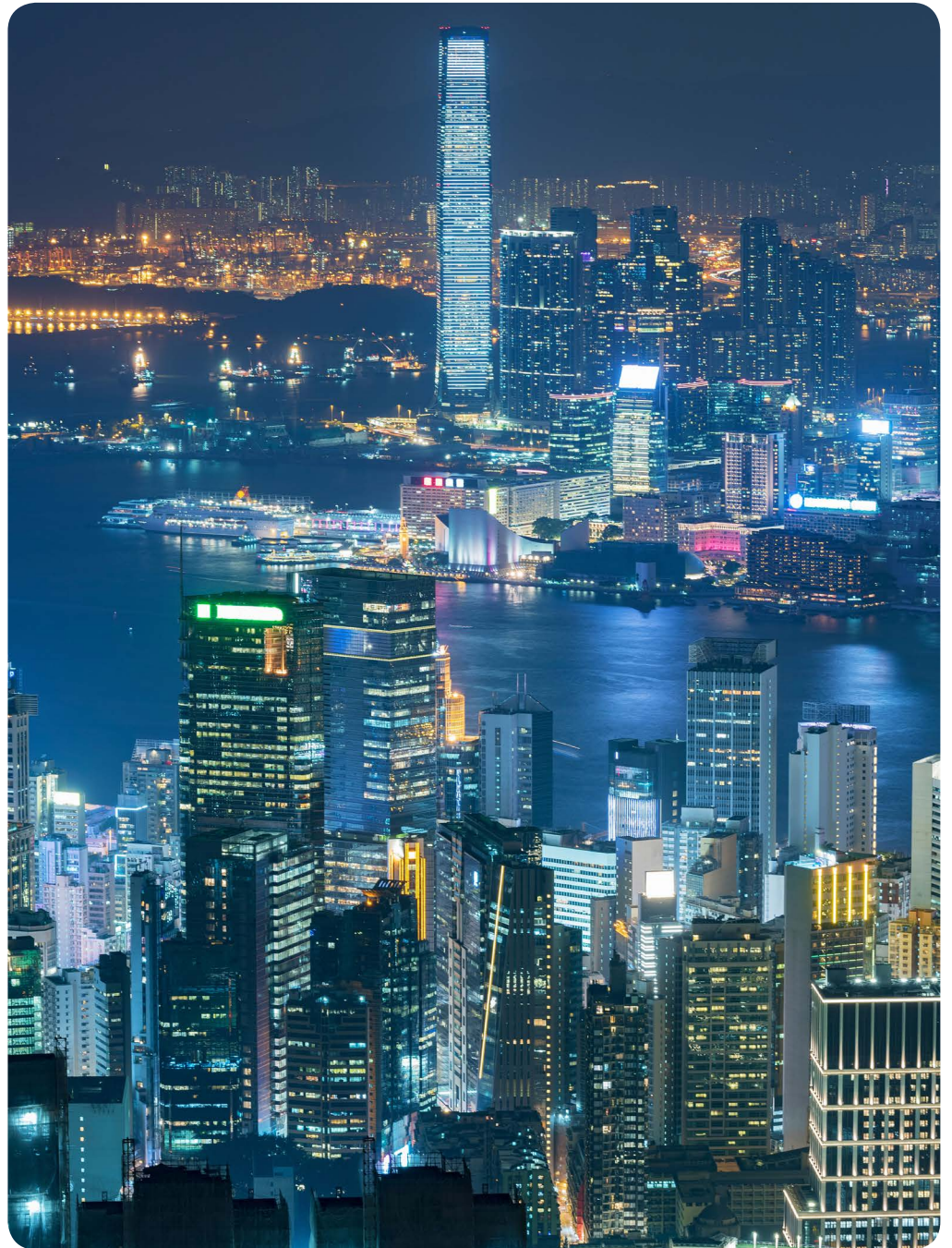

Connecting people and businesses everywhere



150

Years of Experience



+50

Countries



33k

Employees



+15B

Sales in Euros

Sustainability-driven innovation to lead the energy transition and digital transformation

With a legacy spanning over 150 years, Prysmian is a global leader in energy and telecom cable solutions, driving innovation and sustainability. In 2023, we achieved over €15 billion in sales, supported by our 33,000 employees, 82 manufacturing plants, and operations in more than 50 countries worldwide.

We offer the broadest range of cutting-edge products, services, and technologies tailored to meet the evolving needs of our customers. From enabling the energy transition with our pioneering E-Path sustainable cable solution, to supporting critical telecom infrastructure, Prysmian plays a pivotal role in building resilient and efficient systems across the globe.

Our commitment to work closely with our customers ensures that we deliver solutions to help them expand energy and telecom networks, achieving sustainable, profitable growth while addressing the challenges of a rapidly changing world. Together, we're shaping the future of connectivity and electrification.



The planet's pathways

Our world-leading cable solutions



Transmission

- Submarine power and telecom systems
- Marine installation through inhouse fleet
- Underground interconnectors up to 525kV DC
- Complete solutions provider:
 - Turn-key execution approach
 - Continuous monitoring
 - Post-installation maintenance



Power Grid

- HV/EHV AC systems supply and installation
- MV and HV/EHV Network Components (NWC) up to 500kV
- Power Distribution cables' solutions from LV to MV (and up to 69kV)
- Data-driven permanent monitoring systems for power networks



Electrification

- Renewables
- Specialties & OEM
 - (Railway, Marine, Crane, Mining, Nuclear, Rolling Stock, Defence, Electro medical, other infrastructure)
- Data Centres
- Energy Storage Systems
- OGP Onshore/Offshore & SURF
- Elevators
- Other Industrial
- Residential, Hospitals & Commercial constructions



Digital Solutions

- Commercial Buildings
 - Passive Optical Cabling
 - Structured Cabling System
 - Building Management
- Data Centre
- Mission Critical and Harsh Environment
- Broadcast and Studio
- Marine & Shipboard

The planet's pathways

Network components



Empowering Reliable Grids with Comprehensive Network Components

We go beyond cables to deliver complete solutions for your transmission and distribution needs. Our extensive portfolio of network components and accessories—including joints, terminations, connectors, and glands—ensures seamless integration with power systems, whether for new installations or upgrades to existing grids. Engineered to the highest standards, our components provide reliability, safety, and performance, supporting utilities in building efficient and robust power networks.

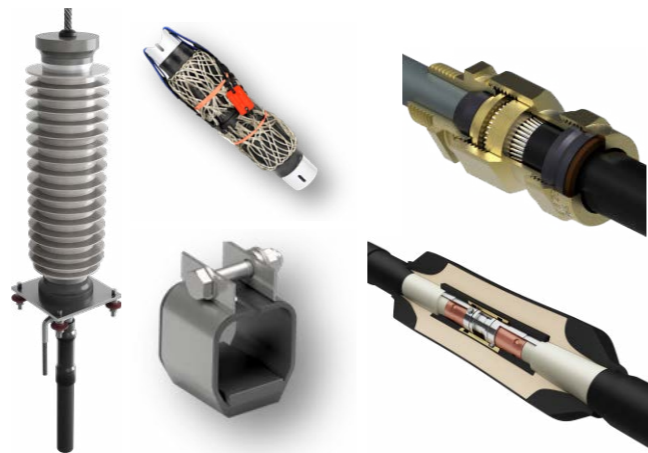

We offer tailored solutions across all voltage classes, including innovative designs for optical fiber integration and asset monitoring systems, reflecting our commitment to sustainability and innovation. Our advanced technologies, such as pre-expanded and cold-shrink options, enable faster, easier installations, reducing downtime and ensuring operational excellence.

Backed by Prysmian's global reach and local expertise, we provide dedicated engineering support and customized designs to meet specific project needs. Together, let's build the future of power systems with network components that are as reliable and innovative as our cables.

Asset monitoring & systems



Advanced Sensing Solutions for Proactive Asset Management

Prysmian's Electronic and Optical Sensing Solutions (EOSS) are at the forefront of system integrity monitoring, offering cutting-edge tools to safeguard your critical assets. Our comprehensive platform integrates partial discharge (PD) detection, distributed temperature sensing (DTS), and distributed acoustic sensing (DAS) to provide real-time insights into your system's health. With Pry-Cam solutions for both portable, spot analysis and permanent installation for continuous monitoring, you hold the power to act proactively, ensuring safety, reliability, and costefficiency.



Our systems deliver precise data on temperature variations, partial discharge activity, and acoustic anomalies, enabling informed decision-making to prevent costly repairs or unplanned downtime. Scalable and flexible, the modular design adapts to your evolving needs, while user-friendly interfaces streamline monitoring and analysis.

With EOSS, Prysmian elevates monitoring from reactive to preventive, helping utilities and industries achieve enhanced operational reliability. Discover how EOSS and Pry-Cam can transform your approach to asset management, ensuring the safety and longevity

Prysmian in the region



Prysmian operates extensively across the Asia Pacific region, supported by a robust infrastructure that includes 13 manufacturing plants across China, Malaysia, Indonesia, the Philippines, and Thailand. Our regional distribution center in Singapore serves as a strategic hub, ensuring seamless delivery of cutting-edge cable solutions for the energy, infrastructure, and telecom markets.

In Asia Pacific, Prysmian is proud to be a part of landmark projects that showcase our expertise and commitment to innovation. These include addressing the complex cable requirements of iconic developments like Marina Bay Sands in Singapore and supporting the ambitious South Vietnam submarine cable projects,

which strengthen regional connectivity. Additionally, Prysmian's advanced solutions have contributed to offshore wind farm developments, highlighting our pivotal role in accelerating the region's transition to renewable energy.

With a clear focus on sustainability and a strong local presence, Prysmian is well-positioned to meet the demands of Asia Pacific's rapidly growing markets. We remain dedicated to delivering innovative technologies that empower our partners and drive the region's progress towards a more connected and

Our corporate brand

Prysmian has a multi-brand architecture made of three levels: a strong Corporate Brand, Prysmian, which stands for the whole organization. It is the umbrella brand under which all the initiatives regarding the Company worldwide are carried out.



The second level is represented by the three well-known Commercial Brands: Prysmian, Draka and General Cable.



The third level encompasses the wide range of product brands that serve all the markets and applications in which the Company operates.



Copper Conductor**1. Copper Cables - Non-Armoured XLPE Insulation (3.6/6 - 18/30 kV)**

1.1	1C CU/XLPE/CTS/PVC – N2XSY	10
1.2	3C CU/XLPE/CTS/PVC – N2XSEY	14

2. Copper Cables - Armoured XLPE Insulation (3.6/6 - 18/30 kV)

2.1	1C CU/XLPE/CTS/PVC/DATA/PVC – N2XSYB(AL)Y	18
2.2	3C CU/XLPE/CTS/PVC/DSTA/PVC – N2XSEYBY	22
2.3	1C CU/XLPE/CTS/PVC/AWA/PVC – N2XSYR(AL)Y	26
2.4	3C CU/XLPE/CTS/PVC/SWA/PVC – N2XSEYRY	30
2.5	3C CU/XLPE/CTS/PVC/SFA/PVC – N2XSEYFY	34

3. Copper Cables - Lead Sheath XLPE Insulation (3.6/6 - 18/30 kV)

3.1	1C CU/XLPE/CTS/PVC/LS/PVC – N2XSKY	38
3.2	3C CU/XLPE/CTS/LS/PVC – N2XSEKY	42
3.3	1C CU/XLPE/CTS/LS/PVC/DATA/PVC – N2XSKB(AL)Y	46
3.4	CU/XLPE/CTS/LS/PVC/DSTA/PVC – N2XSEYBY	50
3.5	1C CU/XLPE/CTS/LS/PVC/AWA/PVC – N2XSKYR(AL)Y	54
3.6	3C CU/XLPE/CTS/LS/PVC/SWA/PVC – N2XSEKRY	58
3.7	3C CU/XLPE/CTS/LS/PVC/SFA/PVC – N2XSEKRY	62

Aluminium Conductor**4. Aluminium Cables - Non-Armoured XLPE Insulation (3.6/6 - 18/30 kV)**

4.1	1C AL/XLPE/CTS/PVC – NA2XSY	66
4.2	3C AL/XLPE/CTS/PVC – NA2XSEY	70

5. Aluminium Cables - Armoured XLPE Insulation (3.6/6 - 18/30 kV)

5.1	1C AL/XLPE/CTS/PVC/DATA/PVC – NA2XSYB(AL)Y	74
5.2	3C AL/XLPE/CTS/PVC/DSTA/PVC – NA2XSEYBY	78
5.3	1C AL/XLPE/CTS/PVC/AWA/PVC – NA2XSYR(AL)Y	82
5.4	3C AL/XLPE/CTS/PVC/SWA/PVC – NA2XSEYRY	86
5.5	AL/XLPE/CTS/PVC/SFA/PVC – NA2XSEYFY	90

6. Aluminium Cables - Lead Sheath XLPE Insulation (3.6/6 - 18/30 kV)

6.1	3C AL/XLPE/CTS/LS/PVC – NA2XSEKY	94
6.2	1C AL/XLPE/CTS/LS/PVC/DATA/PVC – NA2XSKB(AL)Y	98
6.3	3C AL/XLPE/CTS/LS/PVC/DSTA/PVC – NA2XSEKBY	102
6.4	1C AL/XLPE/CTS/LS/PVC/AWA/PVC – NA2XSKR(AL)Y	106
6.5	3C AL/XLPE/CTS/LS/PVC/SWA/PVC – NA2XSEKRY	110
6.6	3C AL/XLPE/CTS/LS/PVC/SFA/PVC – NA2XSEKRY	114

7. AIR BAG™ Polymeric Armored Cable

7.1	1C CU/XLPE/CTS/AB/PVC	124
7.2	3C CU/XLPE/CTS/PVC/AB/PVC	128
7.3	1C AL/XLPE/CTS/AB/PVC	132
7.4	3C AL/XLPE/CTS/PVC/AB/PVC	136

Rating Factors for XLPE/EPR Insulated MV Cables

A.	Cable Laid Direct in Ground	141
B.	Cable Laid Direct in Duct	144
C.	Cable Installed in Free Air	147

Cables and Drums User Guide

1.	Drums handling	151
2.	Transport Requirements	152
3.	Storage Requirements	153
4.	Suggestions for Cable Installation	154

Copper Cable - Non-armoured XLPE Insulation

3.6/6(7.2) - 18/30(36) kV

1C CU/XLPE/CTS/PVC – N2XSY



CONSTRUCTION

Conductor	: Plain annealed copper wire according to IEC 60228 - Class 2 for Stranded Conductors
Conductor Screen	: Extruded Semi Conductive Compound
Insulation	: XLPE Compound
Insulation Screen	: Extruded Semi Conductive Compound
Metallic Screen	: Plain Annealed Copper Tapes
Sheath	: PVC Compound ST 2

APPLICABLE STANDARDS

SNI IEC 60502-2, IEC 60502-2
IEC 60228
IEC 60332-1
IEC 60332-3-22
IEC 60332-3-23
IEC 60332-3-24

Design and Test Guidelines
Conductor
Flame Retardant
Flame Retardant Cat. A
Flame Retardant Cat. B
Flame Retardant Cat. C

Special features on request:
EPR Insulation
Flame Retardant Cat. A, B, C
Flame Retardant Non Category
Anti-termite

Anti-rodent
Oil Resistance
UV Resistance
Low Smoke Zero Halogen

IDENTIFICATIONS

Core Not Applicable



IEC 60332-1
IEC 60332-3-22
IEC 60332-3-23
IEC 60332-3-24



Standard



Excellent



0°C

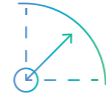

14 D



Normal Operation Temperature



Short Circuit Temperature

Dimension and Electrical Data

Cross Section	Tension U ₀ /U	Conductor Diameter	Insulation Diameter	Metallic Screen Diameter	Outer Sheath Diameter	Cable Weight	Packaging	Max DC Resistance at 20°C	Current Rating in air at 20°C	Current Rating in ground at 20°C	Short Circuit Current for 1s
mm ²	kV	mm	mm	mm	mm	kg/km	m	Ω/km	A	A	kA
1x50	3.6/6	8.2	16	18	22	796	1000	0.3870	238	196	7.2
1x70	3.6/6	9.8	17	18	22	976	1000	0.2680	296	239	10.0
1x95	3.6/6	11.3	18	20	24	1243	1000	0.1930	361	285	13.6
1x120	3.6/6	12.8	20	22	25	1485	1000	0.1530	417	323	17.2
1x150	3.6/6	14.2	21	23	27	1760	1000	0.1240	473	361	21.5
1x185	3.6/6	15.7	23	24	28	2106	1000	0.0991	543	406	26.5
1x240	3.6/6	18.1	26	27	31	2718	1000	0.0754	641	469	34.3
1x300	3.6/6	20.2	27	29	33	3269	1000	0.0601	735	526	42.9
1x400	3.6/6	22.8	30	32	36	4087	1000	0.0470	845	590	57.2
1x500	3.6/6	26.1	33	35	39	5121	500	0.0366	961	668	71.5
1x630	3.6/6	29.9	38	40	45	6622	500	0.0283	1078	734	90.1
1x50	6/10	8.2	17	18	22	810	1000	0.3870	238	196	7.2
1x70	6/10	9.8	17	19	23	985	1000	0.2680	296	239	10.0
1x95	6/10	11.3	19	20	24	1247	1000	0.1930	361	285	13.6
1x120	6/10	12.8	20	22	25	1510	1000	0.1530	417	323	17.2
1x150	6/10	14.2	22	23	27	1776	1000	0.1240	473	361	21.5
1x185	6/10	15.7	24	25	29	2164	1000	0.0991	543	406	26.5
1x240	6/10	18.1	26	27	31	2723	1000	0.0754	641	469	34.3
1x300	6/10	20.2	28	30	33	3305	1000	0.0601	735	526	42.9
1x400	6/10	22.8	30	32	37	4127	1000	0.0470	845	590	57.2
1x500	6/10	26.1	34	36	41	5197	500	0.0366	961	668	71.5
1x630	6/10	29.9	38	40	45	6641	500	0.0283	1078	734	90.1
1x50	8.7/15	8.2	19	20	24	897	1000	0.3870	238	196	7.2
1x70	8.7/15	9.8	19	21	25	1080	1000	0.2680	296	239	10.0
1x95	8.7/15	11.3	21	23	26	1352	1000	0.1930	361	285	13.6
1x120	8.7/15	12.8	22	24	28	1613	1000	0.1530	417	323	17.2
1x150	8.7/15	14.2	24	25	29	1892	1000	0.1240	473	361	21.5
1x185	8.7/15	15.7	26	27	32	2283	1000	0.0991	543	406	26.5
1x240	8.7/15	18.1	28	30	34	2880	1000	0.0754	641	469	34.3
1x300	8.7/15	20.2	30	32	36	3455	1000	0.0601	735	526	42.9
1x400	8.7/15	22.8	33	35	39	4304	500	0.0470	845	590	57.2
1x500	8.7/15	26.1	36	38	43	5336	500	0.0366	961	668	71.5
1x630	8.7/15	29.9	40	42	47	6795	500	0.0283	1078	734	90.1

Dimension and Electrical Data (cont.)

Cross Section	Tension U ₀ /U	Conductor Diameter	Insulation Diameter	Metallic Screen Diameter	Outer Sheath Diameter	Cable Weight	Packaging	Max DC Resistance at 20°C	Current Rating in air at 20°C	Current Rating in ground at 20°C	Short Circuit Current for 1s
mm ²	kV	mm	mm	mm	mm	kg/km	m	Ω/km	A	A	kA
1x50	12/20	8.2	21	22	26	973	1000	0.3870	238	196	7.2
1x70	12/20	9.8	22	23	27	1181	1000	0.2680	296	239	10.0
1x95	12/20	11.3	23	25	29	1472	1000	0.1930	361	285	13.6
1x120	12/20	12.8	25	27	31	1727	1000	0.1530	417	323	17.2
1x150	12/20	14.2	26	28	32	2030	1000	0.1240	473	361	21.5
1x185	12/20	15.7	28	29	34	2384	1000	0.0991	543	406	26.5
1x240	12/20	18.1	30	32	36	2997	1000	0.0754	641	469	34.3
1x300	12/20	20.2	32	34	38	3585	1000	0.0601	735	526	42.9
1x400	12/20	22.8	35	37	41	4444	1000	0.0470	845	590	57.2
1x500	12/20	26.1	38	39	44	5461	500	0.0366	961	668	71.5
1x630	12/20	29.9	42	44	49	6995	500	0.0283	1078	734	90.1
1x50	18/30	8.2	26	27	31	1229	1000	0.3870	238	196	7.2
1x70	18/30	9.8	26	28	32	1412	1000	0.2680	296	239	10.0
1x95	18/30	11.3	28	29	33	1719	1000	0.1930	361	285	13.6
1x120	18/30	12.8	29	31	35	1988	1000	0.1530	417	323	17.2
1x150	18/30	14.2	31	32	37	2292	1000	0.1240	473	361	21.5
1x185	18/30	15.7	32	34	38	2668	500	0.0991	543	406	26.5
1x240	18/30	18.1	34	36	41	3288	1000	0.0754	641	469	34.3
1x300	18/30	20.2	37	39	44	3941	1000	0.0601	735	526	42.9
1x400	18/30	22.8	40	41	47	4806	1000	0.0470	845	590	57.2
1x500	18/30	26.1	43	44	49	5867	500	0.0356	961	668	71.5
1x630	18/30	29.9	47	49	54	7434	500	0.0283	1078	734	90.1

Copper Cable - Non-armoured XLPE Insulation

3.6/6(7.2) - 18/30(36) kV

3C CU/XLPE/CTS/PVC – N2XSEY



CONSTRUCTION

Conductor	: Plain annealed copper wire according to IEC 60228 - Class 2 for Stranded Compacted Conductors
Conductor Screen	: Extruded Semi Conductive Compound
Insulation	: XLPE Compound
Insulation Screen	: Extruded Semi Conductive Compound
Metallic Screen	: Plain Annealed Copper Tapes
Filler	: PP Yarn Filler
Sheath	: PVC Compound ST 2

APPLICABLE STANDARDS

SNI IEC 60502-2, IEC 60502-2
IEC 60228
IEC 60332-1
IEC 60332-3-22
IEC 60332-3-23
IEC 60332-3-24

Design and Test Guidelines
Conductor
Flame Retardant
Flame Retardant Cat. A
Flame Retardant Cat. B
Flame Retardant Cat. C

Special features on request:
EPR Insulation
Flame Retardant Cat. A, B, C
Flame Retardant Non Category
Anti-termite

Anti-rodent
Oil Resistance
UV Resistance
Low Smoke Zero Halogen

IDENTIFICATIONS

Core Brown, Black, Grey

Others colours available upon request



IEC 60332-1
IEC 60332-3-22
IEC 60332-3-23
IEC 60332-3-24



Standard



Excellent



0°C



14 D



Normal
Operation
Temperature



Short
Circuit
Temperature

Dimension and Electrical Data

Cross Section	Tension U ₀ /U	Conductor Diameter	Insulation Diameter	Metallic Screen Diameter	Outer Sheath Diameter	Cable Weight	Packaging	Max DC Resistance at 20°C	Current Rating in air at 20°C	Current Rating in ground at 20°C	Short Circuit Current for 1s
mm ²	kV	mm	mm	mm	mm	kg/km	m	Ω/km	A	A	kA
3x50	3.6/6	8.2	16	18	43	2618	1000	0.3870	204	181	7.2
3x70	3.6/6	9.8	17	19	45	3276	1000	0.2680	253	221	10.0
3x95	3.6/6	11.3	19	21	49	4153	1000	0.1930	304	262	13.6
3x120	3.6/6	12.8	20	22	53	4952	1000	0.1530	351	298	17.2
3x150	3.6/6	14.2	22	23	56	5880	500	0.1240	398	334	21.5
3x185	3.6/6	15.7	23	25	59	7011	500	0.0991	455	377	26.5
3x240	3.6/6	18.1	26	27	65	8899	500	0.0754	531	434	34.3
3x300	3.6/6	20.2	27	29	69	10574	250	0.0601	606	489	42.9
3x50	6/10	8.2	17	18	44	2661	1000	0.3870	204	181	7.2
3x70	6/10	9.8	17	19	45	3270	1000	0.2680	253	221	10.0
3x95	6/10	11.3	19	21	50	4249	1000	0.1930	304	262	13.6
3x120	6/10	12.8	21	22	53	5069	1000	0.1530	351	298	17.2
3x150	6/10	14.2	22	23	56	5841	500	0.1240	398	334	21.5
3x185	6/10	15.7	23	25	59	7008	500	0.0991	455	377	26.5
3x240	6/10	18.1	26	28	66	9034	250	0.0754	531	434	34.3
3x300	6/10	20.2	28	29	70	10756	250	0.0601	606	489	42.9
3x50	8.7/15	8.2	18	19	47	2851	1000	0.3870	204	181	7.2
3x70	8.7/15	9.8	19	21	50	3606	1000	0.2680	253	221	10.0
3x95	8.7/15	11.3	21	23	54	4604	500	0.1930	304	262	13.6
3x120	8.7/15	12.8	23	25	59	5476	500	0.1530	351	298	17.2
3x150	8.7/15	14.2	24	25	61	6218	500	0.1240	398	334	21.5
3x185	8.7/15	15.7	25	27	64	7450	500	0.0991	455	377	26.5
3x240	8.7/15	18.1	28	29	70	9324	250	0.0754	531	434	34.3
3x300	8.7/15	20.2	30	32	75	11246	250	0.0601	606	489	42.9

Dimension and Electrical Data (cont.)

Cross Section	Tension U ₀ /U	Conductor Diameter	Insulation Diameter	Metallic Screen Diameter	Outer Sheath Diameter	Cable Weight	Packaging	Max DC Resistance at 20°C	Current Rating in air at 20°C	Current Rating in ground at 20°C	Short Circuit Current for 1s
mm ²	kV	mm	mm	mm	mm	kg/km	m	Ω/km	A	A	kA
3x50	12/20	8.2	21	22	53	3304	1000	0.3870	204	181	7.2
3x70	12/20	9.8	22	23	56	4095	500	0.2680	253	221	10.0
3x95	12/20	11.3	23	25	58	4853	500	0.1930	304	262	13.6
3x120	12/20	12.8	25	27	63	5903	500	0.1530	351	298	17.2
3x150	12/20	14.2	26	27	65	6690	500	0.1240	398	334	21.5
3x185	12/20	15.7	27	29	69	8204	250	0.0991	455	377	26.5
3x240	12/20	18.1	30	32	76	10087	250	0.0754	531	434	34.3
3x300	12/20	20.2	32	33	80	11812	250	0.0601	606	489	42.9
3x50	18/30	8.2	26	27	65	4397	500	0.3870	204	181	7.2
3x70	18/30	9.8	26	28	66	5014	500	0.2680	253	221	10.0
3x95	18/30	11.3	28	29	70	5888	500	0.1930	304	262	13.6
3x120	18/30	12.8	30	31	75	7161	500	0.1530	351	298	17.2
3x150	18/30	14.2	31	32	77	7856	500	0.1240	398	334	21.5
3x185	18/30	15.7	32	34	80	9111	250	0.0991	455	377	26.5
3x240	18/30	18.1	34	36	86	11081	250	0.0754	531	434	34.3
3x300	18/30	20.2	37	38	91	13139	250	0.0601	606	489	42.9

Copper Cable - Armoured XLPE Insulation

3.6/6(7.2) - 18/30(36) kV

1C CU/XLPE/CTS/PVC/DATA/PVC – N2XSYB(AL)Y

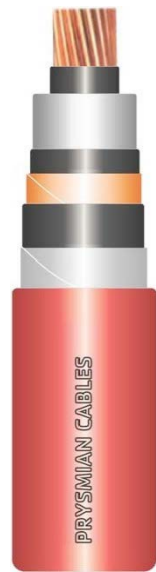

CONSTRUCTION

Conductor	: Plain annealed copper wire according to IEC 60228 - Class 2 for Stranded Compacted Conductors
Conductor Screen	: Extruded Semi Conductive Compound
Insulation	: XLPE Compound
Insulation Screen	: Extruded Semi Conductive Compound
Metallic Screen	: Plain Annealed Copper Tapes
Separation Sheath	: PVC Compound ST 2
Metallic Armour	: Double Aluminium Tapes
Sheath	: PVC Compound ST 2

APPLICABLE STANDARDS

SNI IEC 60502-2, IEC 60502-2
IEC 60228
IEC 60332-1
IEC 60332-3-22
IEC 60332-3-23
IEC 60332-3-24

Design and Test Guidelines
Conductor
Flame Retardant
Flame Retardant Cat. A
Flame Retardant Cat. B
Flame Retardant Cat. C

Special features on request:
EPR Insulation
Flame Retardant Cat. A, B, C
Flame Retardant Non Category
Anti-termite

Anti-rodent
Oil Resistance
UV Resistance
Low Smoke Zero Halogen

IDENTIFICATIONS

Core Not Applicable



IEC 60332-1
IEC 60332-3-22
IEC 60332-3-23
IEC 60332-3-24



Standard



Excellent



0°C



14 D



Normal
Operation
Temperature



Short
Circuit
Temperature

Dimension and Electrical Data

Cross Section	Tension U ₀ /U	Conductor Diameter	Insulation Diameter	Sep. Sheath Diameter	Metallic Screen Diameter	Outer Sheath Diameter	Cable Weight	Packaging	Max DC Resistance at 20°C	Current Rating in air at 20°C	Current Rating in ground at 20°C	Short Circuit Current for 1s
mm ²	kV	mm	mm	mm	mm	mm	kg/km	m	Ω/km	A	A	kA
1x50	3.6/6	8.2	16.2	21	23	27	1068	1000	0.387	238	196	7.2
1x70	3.6/6	9.8	16.8	22	24	28	1282	1000	0.268	296	239	10.0
1x95	3.6/6	11.3	18.3	23	25	28	1530	1000	0.193	361	285	13.6
1x120	3.6/6	12.8	19.8	24	27	30	1796	1000	0.153	417	323	17.2
1x150	3.6/6	14.2	21.6	26	29	32	2133	1000	0.124	473	361	21.5
1x185	3.6/6	15.7	23.1	27	25	32	2395	1000	0.0991	537	462	26.5
1x240	3.6/6	18.1	25.6	30	31	34	2978	1000	0.0754	641	469	34.3
1x300	3.6/6	20.2	27.6	32	34	38	3722	1000	0.0601	735	526	42.9
1x400	3.6/6	22.8	30.3	36	38	42	4672	500	0.047	845	590	57.2
1x500	3.6/6	26.1	33.6	39	41	46	5742	500	0.0366	961	668	71.5
1x630	3.6/6	29.9	37.5	43	45	50	7239	250	0.0283	1078	734	90.1
1x50	6/10	8.2	16.6	21	24	28	1038	1000	0.387	238	196	7.2
1x70	6/10	9.8	17.2	22	24	28	1272	1000	0.268	296	239	10.0
1x95	6/10	11.3	18.7	23	26	29	1566	1000	0.193	361	285	13.6
1x120	6/10	12.8	20.2	25	27	31	1843	1000	0.153	417	323	17.2
1x150	6/10	14.2	21.6	26	28	32	2145	1000	0.124	473	361	21.5
1x185	6/10	15.7	23.1	27	30	34	2534	1000	0.0991	543	406	26.5
1x240	6/10	18.1	25.5	30	32	36	3112	1000	0.0754	641	469	34.3
1x300	6/10	20.2	27.6	32	35	39	3749	1000	0.0601	735	526	42.9
1x400	6/10	22.8	30.2	35	38	42	4638	1000	0.047	845	590	57.2
1x500	6/10	26.1	33.5	38	41	45	5723	500	0.0366	961	668	71.5
1x630	6/10	29.9	38.5	43	46	50	7336	500	0.0283	1078	734	90.1
1x50	8.7/15	8.2	18.7	24	24	28	1112	1000	0.387	238	196	7.2
1x70	8.7/15	9.8	19.3	24	25	29	1310	1000	0.268	296	239	10.0
1x95	8.7/15	11.3	21.4	26	27	31	1627	1000	0.193	361	285	13.6
1x120	8.7/15	12.8	22.3	27	24	33	1963	1000	0.153	407	366	17.2
1x150	8.7/15	14.2	23.7	28	29	33	2144	1000	0.124	473	361	21.5
1x185	8.7/15	15.7	25.2	30	32	36	2651	1000	0.0991	543	406	26.5
1x240	8.7/15	18.1	27.6	32	35	39	3302	1000	0.0754	641	469	34.3
1x300	8.7/15	20.2	30.2	36	38	42	3982	500	0.0601	735	526	42.9
1x400	8.7/15	22.8	32.4	37	40	44	4796	500	0.047	845	590	57.2
1x500	8.7/15	26.1	35.7	40	43	48	5891	500	0.0366	961	668	71.5
1x630	8.7/15	29.9	40.0	45	48	53	7462	250	0.0283	1078	734	90.1

Dimension and Electrical Data (cont.)

Cross Section	Tension Uo/U	Conductor Diameter	Insulation Diameter	Sep. Sheath Diameter	Metallic Screen Diameter	Outer Sheath Diameter	Cable Weight	Packaging	Max DC Resistance at 20°C	Current Rating in air at 20°C	Current Rating in ground at 20°C	Short Circuit Current for 1s
mm ²	kV	mm	mm	mm	mm	mm	kg/km	m	Ω/km	A	A	kA
1x50	12/20	8.2	19.6	24	27	30	1253	1000	0.387	238	196	7.2
1x70	12/20	9.8	21.2	26	27	31	1416	1000	0.268	296	239	10.0
1x95	12/20	11.3	22.8	28	30	34	1813	1000	0.193	361	285	13.6
1x120	12/20	12.8	24.3	29	31	36	2107	1000	0.153	417	323	17.2
1x150	12/20	14.2	25.6	30	33	37	2407	1000	0.124	473	361	21.5
1x185	12/20	15.7	27.2	32	34	39	2807	1000	0.0991	543	406	26.5
1x240	12/20	18.1	29.6	34	37	42	3476	1000	0.0754	641	469	34.3
1x300	12/20	20.2	31.7	37	39	44	4127	1000	0.0601	735	526	42.9
1x400	12/20	22.8	34.3	39	42	47	4976	500	0.047	845	590	57.2
1x500	12/20	26.1	37.6	42	45	so	6084	500	0.0366	961	668	71.5
1x630	12/20	29.9	41.9	47	50	55	7696	250	0.0283	1078	734	90.1
1x50	18/30	8.2	24.5	29	31	35	1568	1000	0.387	238	196	7.2
1x70	18/30	9.8	26.1	31	33	37	1842	1000	0.268	296	239	10.0
1x95	18/30	11.3	27.7	32	35	39	2181	1000	0.193	361	285	13.6
1x120	18/30	12.8	29.1	34	36	41	2497	1000	0.153	417	323	17.2
1x150	18/30	14.2	30.5	35	38	42	2790	1000	0.124	473	361	21.5
1x185	18/30	15.7	32.0	37	40	44	3235	1000	0.0991	543	406	26.5
1x240	18/30	18.1	34.4	39	42	46	3854	1000	0.0754	641	469	34.3
1x300	18/30	20.2	36.6	41	44	48	4501	500	0.0601	735	526	42.9
1x400	18/30	22.8	39.2	44	46	51	5385	500	0.047	845	590	57.2
1x500	18/30	26.1	42.5	47	50	55	6547	500	0.0366	961	668	71.5
1x630	18/30	29.9	47.4	52	55	60	8265	500	0.0283	1078	734	90.1

Copper Cable - Armoured XLPE Insulation

3.6/6(7.2) - 18/30(36) kV

3C CU/XLPE/CTS/PVC/DSTA/PVC – N2XSEYBY

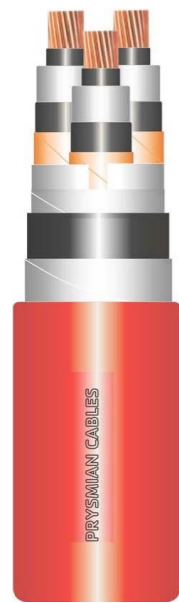

CONSTRUCTION

Conductor	: Plain annealed copper wire according to IEC 60228 - Class 2 for Stranded Compacted Conductors
Conductor Screen	: Extruded Semi Conductive Compound
Insulation	: XLPE Compound
Insulation Screen	: Extruded Semi Conductive Compound
Metallic Screen	: Plain Annealed Copper Tapes
Filler	: PP Yarn Filler
Separation Sheath	: PVC ST2 Compound
Metallic Armour	: Double Galvanized Steel Tapes
Sheath	: PVC ST2 Compound

APPLICABLE STANDARDS

SNI IEC 60502-2, IEC 60502-2
IEC 60228
IEC 60332-1
IEC 60332-3-22
IEC 60332-3-23
IEC 60332-3-24

Design and Test Guidelines
Conductor
Flame Retardant
Flame Retardant Cat. A
Flame Retardant Cat. B
Flame Retardant Cat. C

Special features on request:
EPR Insulation
Flame Retardant Cat. A, B, C
Flame Retardant Non Category
Anti-termites

Anti-rodent
Oil Resistance
UV Resistance
Low Smoke Zero Halogen

IDENTIFICATIONS

Core: Brown, Black, Grey

Others colours available upon request



IEC 60332-1
IEC 60332-3-22
IEC 60332-3-23
IEC 60332-3-24



Standard



Excellent



0°C



14 D



Normal
Operation
Temperature



Short
Circuit
Temperature

Dimension and Electrical Data

Cross Section	Tension U ₀ /U	Conductor Diameter	Insulation Diameter	Sep. Sheath Diameter	Metallic Screen Diameter	Outer Sheath Diameter	Cable Weight	Packaging	Max DC Resistance at 20°C	Current Rating in air at 20°C	Current Rating in ground at 20°C	Short Circuit Current for 1s
mm ²	kV	mm	mm	mm	mm	mm	kg/km	m	Ω/km	A	A	kA
3x50	3.6/6	8.2	16.2	42	44	48	3592	1000	0.387	205	181	7.2
3x70	3.6/6	9.8	16.8	43	45	50	4167	1000	0.268	253	220	10.0
3x95	3.6/6	11.3	18.3	46	49	53	5167	1000	0.193	307	263	13.6
3x120	3.6/6	12.8	19.8	49	52	57	6057	500	0.153	352	298	17.2
3x150	3.6/6	14.2	21.6	53	56	62	7667	500	0.124	397	332	21.5
3x185	3.6/6	15.7	23.2	57	59	65	8427	500	0.0991	453	374	26.5
3x240	3.6/6	18.1	25.6	62	64	71	10554	250	0.0754	529	431	34.3
3x300	3.6/6	20.2	27.2	66	68	75	12330	250	0.0601	599	482	42.9
3x50	6/10	8.2	16.6	42	45	49	3692	1000	0.387	205	181	7.2
3x70	6/10	9.8	17.2	43	46	51	4317	1000	0.268	253	220	10.0
3x95	6/10	11.3	18.7	47	49	55	5151	500	0.193	307	263	13.6
3x120	6/10	12.8	20.2	50	52	58	6208	500	0.153	352	298	17.2
3x150	6/10	14.2	21.6	53	55	62	7240	500	0.124	397	332	21.5
3x185	6/10	15.7	23.1	56	59	65	8343	500	0.0991	453	374	26.5
3x240	6/10	18.1	26.0	63	65	72	10656	250	0.0754	529	431	34.3
3x300	6/10	20.2	27.6	67	69	76	12496	250	0.0601	599	482	42.9
3x50	8.7/15	8.2	17.7	44	47	52	3907	500	0.387	205	181	7.2
3x70	8.7/15	9.8	19.3	48	51	57	4912	500	0.268	253	220	10.0
3x95	8.7/15	11.3	20.9	0	54	60	6707	500	0.193	307	263	13.6
3x120	8.7/15	12.8	20.7	51	54	59	6438	500	0.153	352	298	17.2
3x150	8.7/15	14.2	23.7	58	60	66	7673	500	0.124	397	332	21.5
3x185	8.7/15	15.7	23.6	58	60	66	8636	500	0.0991	453	374	26.5
3x240	8.7/15	18.1	27.6	66	69	76	11018	250	0.0754	529	431	34.3
3x300	8.7/15	20.2	28.1	68	70	77	12759	250	0.0601	599	482	42.9

Dimension and Electrical Data (cont.)

Cross Section	Tension Uo/U	Conductor Diameter	Insulation Diameter	Sep. Sheath Diameter	Metallic Screen Diameter	Outer Sheath Diameter	Cable Weight	Packaging	Max DC Resistance at 20°C	Current Rating in air at 20°C	Current Rating in ground at 20°C	Short Circuit Current for 1s
mm ²	kV	mm	mm	mm	mm	mm	kg/km	m	Ω/km	A	A	kA
3x50	12/20	8.2	20.6	51	53	59	4662	1000	0.387	205	181	7.2
3x70	12/20	9.8	21.7	54	56	62	5442	500	0.268	253	220	10.0
3x95	12/20	11.3	23.3	57	59	65	6440	500	0.193	307	263	13.6
3x120	12/20	12.8	24.8	60	63	69	7419	250	0.153	352	298	17.2
3x150	12/20	14.2	26.1	63	66	72	8450	250	0.124	397	332	21.5
3x185	12/20	15.7	27.6	67	69	76	9794	250	0.0991	453	374	26.5
3x240	12/20	18.1	30.1	72	76	83	12704	250	0.0754	529	431	34.3
3x300	12/20	20.2	32.2	77	81	88	14820	250	0.0601	599	482	42.9
3x50	18/30	8.2	25.0	61	63	69	5894	250	0.387	205	181	7.2
3x70	18/30	9.8	26.1	63	66	72	6560	500	0.268	253	220	10.0
3x95	18/30	11.3	27.7	67	69	76	7630	500	0.193	307	263	13.6
3x120	18/30	12.8	34.7	82	86	94	11327	250	0.153	352	298	17.2
3x150	18/30	14.2	36.0	86	90	98	12523	250	0.124	397	332	21.5
3x185	18/30	15.7	32.5	78	82	89	12271	250	0.0991	453	374	26.5
3x240	18/30	18.1	34.9	83	87	95	14542	250	0.0754	529	431	34.3
3x300	18/30	20.2	37.0	88	92	100	16758	250	0.0601	599	482	42.9

Copper Cable - Armoured XLPE Insulation

3.6/6(7.2) - 18/30(36) kV

1C CU/XLPE/CTS/PVC/AWA/PVC – N2XS(YR(AL)Y



CONSTRUCTION

Conductor	: Plain annealed copper wire according to IEC 60228 - Class 2 for Stranded Compacted Conductors
Conductor Screen	: Extruded Semi Conductive Compound
Insulation	: XLPE Compound
Insulation Screen	: Extruded Semi Conductive Compound
Metallic Screen	: Plain Annealed Copper Tapes
Separation Sheath	: PVC Compound ST 2
Metallic Armour	: Aluminium Wires Armour
Sheath	: PVC Compound ST 2

APPLICABLE STANDARDS

SNI IEC 60502-2, IEC 60502-2
IEC 60228
IEC 60332-1
IEC 60332-3-22
IEC 60332-3-23
IEC 60332-3-24

Design and Test Guidelines
Conductor
Flame Retardant
Flame Retardant Cat. A
Flame Retardant Cat. B
Flame Retardant Cat. C

Special features on request:
EPR Insulation
Flame Retardant Cat. A, B, C
Flame Retardant Non Category
Anti-termite

Anti-rodent
Oil Resistance
UV Resistance
Low Smoke Zero Halogen

IDENTIFICATIONS

Core Not Applicable

Others colours available upon request



IEC 60332-1
IEC 60332-3-22
IEC 60332-3-23
IEC 60332-3-24



Standard



Excellent



0°C



14 D



Normal Operation Temperature



Short Circuit Temperature

Dimension and Electrical Data

Cross Section	Tension U ₀ /U	Conductor Diameter	Insulation Diameter	Sep. Sheath Diameter	Metallic Screen Diameter	Outer Sheath Diameter	Cable Weight	Packaging	Max DC Resistance at 20°C	Current Rating in air at 20°C	Current Rating in ground at 20°C	Short Circuit Current for 1s
mm ²	kV	mm	mm	mm	mm	mm	kg/km	m	Ω/km	A	A	kA
1x50	3.6/6	8.2	16.2	21	24	28	1181	1000	0.387	238	196	7.2
1x70	3.6/6	9.8	16.8	22	24	28	1351	500	0.268	296	239	10.0
1x95	3.6/6	11.3	18.3	23	26	30	1672	1000	0.193	361	285	13.6
1x120	3.6/6	12.8	19.8	25	29	33	2032	1000	0.153	417	323	17.2
1x150	3.6/6	14.2	21.6	26	30	34	2285	1000	0.124	473	361	21.5
1x185	3.6/6	15.7	23.2	28	32	37	2759	1000	0.0991	537	462	26.5
1x240	3.6/6	18.1	25.6	30	34	39	3373	1000	0.0754	641	469	34.3
1x300	3.6/6	20.2	27.6	33	37	42	4040	1000	0.0601	735	526	42.9
1x400	3.6/6	22.8	29.8	35	39	44	4899	1000	0.047	845	590	57.2
1x500	3.6/6	26.1	33.5	39	44	49	6186	500	0.0366	961	668	71.5
1x630	3.6/6	29.9	38.0	43	48	54	7782	500	0.0283	1078	734	90.1
1x50	6/10	8.2	16.6	21	24	28	1204	1000	0.387	238	196	7.2
1x70	6/10	9.8	17.2	22	25	28	1387	1000	0.268	296	239	10.0
1x95	6/10	11.3	18.7	23	26	30	1680	1000	0.193	361	285	13.6
1x120	6/10	12.8	20.2	25	29	33	2051	1000	0.153	417	323	17.2
1x150	6/10	14.2	22.0	27	31	35	2390	1000	0.124	473	361	21.5
1x185	6/10	15.7	23.1	28	32	36	2760	1000	0.0991	543	406	26.5
1x240	6/10	18.1	26.0	31	35	39	3415	1000	0.0754	641	469	34.3
1x300	6/10	20.2	28.1	33	37	42	4048	1000	0.0601	735	526	42.9
1x400	6/10	22.8	30.7	36	41	46	5118	1000	0.047	845	590	57.2
1x500	6/10	26.1	34.0	39	44	49	6231	500	0.0366	961	668	71.5
1x630	6/10	29.9	38.5	43	48	54	7854	500	0.0283	1078	734	90.1
1x50	8.7/15	8.2	18.7	23	27	31	1333	500	0.387	238	196	7.2
1x70	8.7/15	9.8	19.3	23	27	30	1483	500	0.268	296	239	10.0
1x95	8.7/15	11.3	21.4	26	30	34	1978	500	0.193	361	285	13.6
1x120	8.7/15	12.8	22.3	27	31	35	2205	500	0.153	407	366	17.2
1x150	8.7/15	14.2	23.7	28	32	36	2519	500	0.124	473	361	21.5
1x185	8.7/15	15.7	25.7	30	34	39	2940	1000	0.0991	543	406	26.5
1x240	8.7/15	18.1	27.6	33	37	42	3629	1000	0.0754	641	469	34.3
1x300	8.7/15	20.2	29.8	35	39	44	4264	1000	0.0601	735	526	42.9
1x400	8.7/15	22.8	32.8	38	43	48	5326	500	0.047	845	590	57.2
1x500	8.7/15	26.1	36.1	41	46	52	6513	500	0.0366	961	668	71.5
1x630	8.7/15	29.9	40.0	45	50	56	7985	500	0.0283	1078	734	90.1

Dimension and Electrical Data (cont.)

Cross Section	Tension U ₀ /U	Conductor Diameter	Insulation Diameter	Sep. Sheath Diameter	Metallic Screen Diameter	Outer Sheath Diameter	Cable Weight	Packaging	Max DC Resistance at 20°C	Current Rating in air at 20°C	Current Rating in ground at 20°C	Short Circuit Current for 1s
mm ²	kV	mm	mm	mm	mm	mm	kg/km	m	Ω/km	A	A	kA
1x50	12/20	8.2	20.6	25	29	33	1460	1000	0.387	238	196	7.2
1x70	12/20	9.8	21.7	26	30	34	1769	1000	0.268	296	239	10.0
1x95	12/20	11.3	22.8	28	32	36	2053	1000	0.193	361	285	13.6
1x120	12/20	12.8	24.3	29	33	38	2360	1000	0.153	417	323	17.2
1x150	12/20	14.2	25.6	30	34	39	2661	1000	0.124	473	361	21.5
1x185	12/20	15.7	27.6	32	36	41	3109	1000	0.0991	543	406	26.5
1x240	12/20	18.1	30.1	35	39	44	3817	1000	0.0754	641	469	34.3
1x300	12/20	20.2	32.2	38	43	48	4592	1000	0.0601	735	526	42.9
1x400	12/20	22.8	34.8	40	45	50	5518	500	0.047	845	590	57.2
1x500	12/20	26.1	38.1	43	48	54	6661	500	0.0366	961	668	71.5
1x630	12/20	29.9	41.9	47	52	58	8262	500	0.0283	1078	734	90.1
1x50	18/30	8.2	25.5	30	34	39	1899	1000	0.387	238	1196	7.2
1x70	18/30	9.8	26.6	31	35	39	2117	1000	0.268	296	239	10.0
1x95	18/30	11.3	27.7	33	37	42	2469	1000	0.193	361	285	13.6
1x120	18/30	12.8	29.1	34	38	43	2768	1000	0.153	417	323	17.2
1x150	18/30	14.2	30.5	36	41	46	3237	1000	0.124	473	361	21.5
1x185	18/30	15.7	32.0	37	42	48	3661	500	0.0991	543	406	26.5
1x240	18/30	18.1	34.4	40	45	50	4360	500	0.0754	641	469	34.3
1x300	18/30	20.2	37.0	42	47	53	5063	1000	0.0601	735	526	42.9
1x400	18/30	22.8	39.2	44	49	55	5943	500	0.047	845	590	57.2
1x500	18/30	26.1	42.9	48	53	59	7168	500	0.0366	961	668	71.5
1x630	18/30	29.9	47.4	53	58	64	8853	500	0.0283	1078	734	90.1

Copper Cable - Armoured XLPE Insulation

3.6/6(7.2) - 18/30(36) kV

3C CU/XLPE/CTS/PVC/SWA/PVC – N2XSEYRY

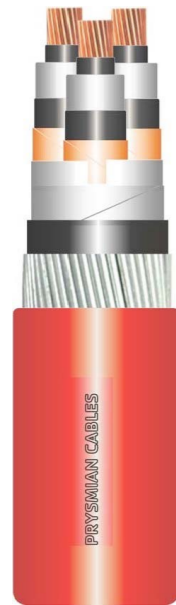

CONSTRUCTION

Conductor	: Plain annealed copper wire according to IEC 60228 - Class 2 for Stranded Compacted Conductors
Conductor Screen	: Extruded Semi Conductive Compound
Insulation	: XLPE Compound
Insulation Screen	: Extruded Semi Conductive Compound
Metallic Screen	: Plain Annealed Copper Tapes
Filler	: PP Yarn Filler
Separation Sheath	: PVC ST2 Compound
Metallic Armour	: Galvanized Steel Wires Armour
Sheath	: PVC ST2 Compound

APPLICABLE STANDARDS

SNI IEC 60502-2, IEC 60502-2
IEC 60228
IEC 60332-1
IEC 60332-3-22
IEC 60332-3-23
IEC 60332-3-24

Special features on request:
EPR Insulation
Flame Retardant Cat. A, B, C
Flame Retardant Non Category
Anti-termite

Design and Test Guidelines
Conductor
Flame Retardant
Flame Retardant Cat. A
Flame Retardant Cat. B
Flame Retardant Cat. C

Anti-rodent
Oil Resistance
UV Resistance
Low Smoke Zero Halogen

IDENTIFICATIONS

Core: Brown, Black, Grey

Others colours available upon request



IEC 60332-1
IEC 60332-3-22
IEC 60332-3-23
IEC 60332-3-24



Standard



Excellent



0°C



14 D



Normal Operation Temperature



Short Circuit Temperature

Dimension and Electrical Data

Cross Section	Tension U ₀ /U	Conductor Diameter	Insulation Diameter	Sep. Sheath Diameter	Metallic Screen Diameter	Outer Sheath Diameter	Cable Weight	Packaging	Max DC Resistance at 20°C	Current Rating in air at 20°C	Current Rating in ground at 20°C	Short Circuit Current for 1s
mm ²	kV	mm	mm	mm	mm	mm	kg/km	m	Ω/km	A	A	kA
3x50	3.6/6	8.2	16.2	41	46	52	4797	500	0.387	205	181	7.2
3x70	3.6/6	9.8	16.8	43	48	53	5424	500	0.268	253	220	10.0
3x95	3.6/6	11.3	18.3	46	51	57	6626	500	0.193	307	263	13.6
3x120	3.6/6	12.8	20.3	50	55	61	7628	500	0.153	352	298	17.2
3x150	3.6/6	14.2	21.6	53	58	65	8745	250	0.124	397	332	21.5
3x185	3.6/6	15.7	22.7	55	60	67	9888	500	0.0991	453	374	26.5
3x240	3.6/6	18.1	25.1	61	67	74	12666	250	0.0754	529	431	34.3
3x300	3.6/6	20.2	27.2	66	72	79	14875	250	0.0601	599	482	42.9
3x50	6/10	8.2	16.6	42	47	53	4985	1000	0.387	205	181	7.2
3x70	6/10	9.8	17.6	45	50	56	5739	500	0.268	253	220	10.0
3x95	6/10	11.3	19.2	48	53	59	6810	500	0.193	307	263	13.6
3x120	6/10	12.8	20.7	51	56	62	7777	500	0.153	352	298	17.2
3x150	6/10	14.2	22.0	54	59	66	8828	500	0.124	397	332	21.5
3x185	6/10	15.7	23.6	58	63	69	10170	500	0.0991	453	374	26.5
3x240	6/10	18.1	26.0	63	69	76	13147	250	0.0754	529	431	34.3
3x300	6/10	20.2	28.1	68	74	81	15357	250	0.0601	599	482	42.9
3x50	8.7/15	8.2	18.7	47	52	58	5491	500	0.387	205	181	7.2
3x70	8.7/15	9.8	19.8	49	54	60	6330	500	0.268	253	220	10.0
3x95	8.7/15	11.3	21.4	53	58	64	7468	500	0.193	307	263	13.6
3x120	8.7/15	12.8	22.8	56	61	68	8566	250	0.153	352	298	17.2
3x150	8.7/15	14.2	23.7	58	64	71	10186	250	0.124	397	332	21.5
3x185	8.7/15	15.7	25.2	61	67	75	11675	250	0.0991	453	374	26.5
3x240	8.7/15	18.1	27.6	67	73	81	13919	250	0.0754	529	431	34.3
3x300	8.7/15	20.2	29.8	71	78	86	16182	250	0.0601	599	482	42.9

Dimension and Electrical Data (cont.)

Cross Section	Tension Uo/U	Conductor Diameter	Insulation Diameter	Sep. Sheath Diameter	Metallic Screen Diameter	Outer Sheath Diameter	Cable Weight	Packaging	Max DC Resistance at 20°C	Current Rating in air at 20°C	Current Rating in ground at 20°C	Short Circuit Current for 1s
mm ²	kV	mm	mm	mm	mm	mm	kg/km	m	Ω/km	A	A	kA
3x50	12/20	8.2	20.6	51	56	62	6093	500	0.387	205	181	7.2
3x70	12/20	9.8	21.2	52	57	65	7015	500	0.268	253	220	10.0
3x95	12/20	11.3	22.8	56	61	68	7894	500	0.193	307	263	13.6
3x120	12/20	12.8	24.8	60	67	74	10087	250	0.153	352	298	17.2
3x150	12/20	14.2	26.1	63	70	77	11251	250	0.124	397	332	21.5
3x185	12/20	15.7	27.6	67	73	81	12533	250	0.0991	453	374	26.5
3x240	12/20	18.1	30.1	72	78	86	15007	250	0.0754	529	431	34.3
3x300	12/20	20.2	31.7	76	82	90	17071	250	0.0601	599	482	42.9
3x50	18/30	8.2	25.5	62	68	75	8449	500	0.387	205	181	7.2
3x70	18/30	9.8	26.1	63	70	77	9390	250	0.268	253	220	10.0
3x95	18/30	11.3	28.2	68	74	82	10612	250	0.193	307	263	13.6
3x120	18/30	12.8	29.1	70	76	84	11495	250	0.153	352	298	17.2
3x150	18/30	14.2	30.5	75	81	90	13172	250	0.124	397	332	21.5
3x185	18/30	15.7	32.5	78	84	92	14458	250	0.0991	453	374	26.5
3x240	18/30	18.1	34.9	83	89	98	16955	250	0.0754	529	431	34.3
3x300	18/30	20.2	37.0	88	94	103	19023	250	0.0601	599	482	42.9

Copper Cable - Armoured XLPE Insulation

3.6/6(7.2) - 18/30(36) kV

3C CU/XLPE/CTS/PVC/SFA/PVC – N2XSEYFY

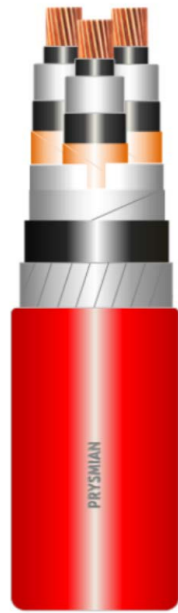

CONSTRUCTION

Conductor	: Plain annealed copper wire according to IEC 60228 - Class 2 for Stranded Compacted Conductors
Conductor Screen	: Extruded Semi Conductive Compound
Insulation	: XLPE Compound
Insulation Screen	: Extruded Semi Conductive Compound
Metallic Screen	: Plain Annealed Copper Tapes
Filler	: PP Yarn Filler
Separation Sheath	: PVC ST2 Compound
Metallic Armour	: Galvanized Steel Flat Armour
Sheath	: PVC ST2 Compound

APPLICABLE STANDARDS

SNI IEC 60502-2, IEC 60502-2
IEC 60228
IEC 60332-1
IEC 60332-3-22
IEC 60332-3-23
IEC 60332-3-24

Special features on request:
EPR Insulation
Flame Retardant Cat. A, B, C
Flame Retardant Non Category
Anti-termite

Design and Test Guidelines
Conductor
Flame Retardant
Flame Retardant Cat. A
Flame Retardant Cat. B
Flame Retardant Cat. C

Anti-rodent
Oil Resistance
UV Resistance
Low Smoke Zero Halogen

IDENTIFICATIONS

Core Brown, Black, Grey

Others colours available upon request



IEC 60332-1
IEC 60332-3-22
IEC 60332-3-23
IEC 60332-3-24



Standard



Excellent



0°C



14 D



Normal
Operation
Temperature



Short
Circuit
Temperature

Dimension and Electrical Data

Cross Section	Tension U ₀ /U	Conductor Diameter	Insulation Diameter	Sep. Sheath Diameter	Metallic Screen Diameter	Outer Sheath Diameter	Cable Weight	Packaging	Max DC Resistance at 20°C	Current Rating in air at 20°C	Current Rating in ground at 20°C	Short Circuit Current for 1s
mm ²	kV	mm	mm	mm	mm	mm	kg/km	m	Ω/km	A	A	kA
3x50	3.6/6	8.2	16.2	42	43	48	3729	1000	0.387	205	181	7.2
3x70	3.6/6	9.8	17.2	44	45	51	4845	1000	0.268	253	220	10.0
3x95	3.6/6	11.3	18.3	46	48	53	5422	500	0.193	307	263	13.6
3x120	3.6/6	12.8	20.3	51	52	58	6352	500	0.153	352	298	17.2
3x150	3.6/6	14.2	21.6	53	55	61	7334	500	0.124	397	332	21.5
3x185	3.6/6	15.7	23.2	57	58	65	8685	500	0.0991	453	374	26.5
3x240	3.6/6	18.1	25.6	62	64	70	10601	250	0.0754	529	431	34.3
3x300	3.6/6	20.2	27.7	67	68	75	12655	250	0.0601	599	482	42.9
3x50	6/10	8.2	15.6	40	42	47	3657	1000	0.387	205	181	7.2
3x70	6/10	9.8	17.2	44	45	51	4529	1000	0.268	253	220	10.0
3x95	6/10	11.3	18.7	47	48	54	5671	500	0.193	307	263	13.6
3x120	6/10	12.8	20.2	50	52	58	6435	500	0.153	352	298	17.2
3x150	6/10	14.2	21.6	53	55	61	7342	500	0.124	397	332	21.5
3x185	6/10	15.7	23.1	56	58	65	9193	500	0.0991	453	374	26.5
3x240	6/10	18.1	25.5	62	63	70	10539	250	0.0754	529	431	34.3
3x300	6/10	20.2	27.6	67	68	76	12680	250	0.0601	599	482	42.9
3x50	8.7/15	8.2	18.7	47	49	54	4380	500	0.387	205	181	7.2
3x70	8.7/15	9.8	19.3	48	50	56	4977	500	0.268	253	220	10.0
3x95	8.7/15	11.3	20.9	51	53	59	5992	500	0.193	307	263	13.6
3x120	8.7/15	12.8	22.8	56	58	64	7062	500	0.153	352	298	17.2
3x150	8.7/15	14.2	23.7	58	59	66	7877	500	0.124	397	332	21.5
3x185	8.7/15	15.7	25.2	61	63	70	9179	500	0.0991	453	374	26.5
3x240	8.7/15	18.1	27.6	67	68	76	11246	250	0.0754	529	431	34.3
3x300	8.7/15	20.2	29.8	71	73	81	13313	250	0.0601	599	482	42.9

Dimension and Electrical Data (cont.)

Cross Section	Tension U ₀ /U	Conductor Diameter	Insulation Diameter	Sep. Sheath Diameter	Metallic Screen Diameter	Outer Sheath Diameter	Cable Weight	Packaging	Max DC Resistance at 20°C	Current Rating in air at 20°C	Current Rating in ground at 20°C	Short Circuit Current for 1s
mm ²	kV	mm	mm	mm	mm	mm	kg/km	m	Ω/km	A	A	kA
3x50	12/20	8.2	20.6	51	53	59	4828	500	0.387	205	181	7.2
3x70	12/20	9.8	21.2	52	54	60	5408	500	0.268	253	220	10.0
3x95	12/20	11.3	23.3	57	59	65	6587	500	0.193	307	263	13.6
3x120	12/20	12.8	24.8	60	62	69	7579	250	0.153	352	298	17.2
3x150	12/20	14.2	25.6	62	64	71	8434	250	0.124	397	332	21.5
3x185	12/20	15.7	26.1	63	65	72	8784	250	0.0991	453	374	26.5
3x240	12/20	18.1	30.1	72	74	81	12232	250	0.0754	529	431	34.3
3x300	12/20	20.2	32.2	81	83	91	14945	250	0.0601	599	482	42.9
3x50	18/30	8.2	24.5	60	61	68	6112	500	0.387	205	181	7.2
3x70	18/30	9.8	26.6	64	66	73	7306	500	0.268	253	220	10.0
3x95	18/30	11.3	28.2	68	69	77	8386	500	0.193	307	263	13.6
3x120	18/30	12.8	29.6	71	73	80	9480	500	0.153	352	298	17.2
3x150	18/30	14.2	31.0	74	76	83	10572	250	0.124	397	332	21.5
3x185	18/30	15.7	32.5	78	79	87	11959	250	0.0991	453	374	26.5
3x240	18/30	18.1	34.9	83	85	93	14245	250	0.0754	529	431	34.3
3x300	18/30	20.2	37.0	88	89	98	16476	250	0.0601	599	482	42.9

Copper Cable - Lead Sheath XLPE Insulation

3.6/6(7.2) - 18/30(36) kV

1C CU/XLPE/CTS/PVC/LS/PVC – N2XSKY



CONSTRUCTION

Conductor	: Plain annealed copper wire according to IEC 60228 - Class 2 for Stranded Compacted Conductors
Conductor Screen	: Extruded Semi Conductive Compound
Insulation	: XLPE Compound
Insulation Screen	: Extruded Semi Conductive Compound
Metallic Screen	: Plain Annealed Copper Tapes
Separation Sheath	: PVC Compound ST 2
Metallic Sheath	: Lead Alloy Sheath
Sheath	: PVC Compound ST 2

APPLICABLE STANDARDS

SNI IEC 60502-2, IEC 60502-2
IEC 60228
IEC 60332-1
IEC 60332-3-22
IEC 60332-3-23
IEC 60332-3-24

Design and Test Guidelines
Conductor
Flame Retardant
Flame Retardant Cat. A
Flame Retardant Cat. B
Flame Retardant Cat. C

Special features on request:
EPR Insulation
Flame Retardant Cat. A, B, C
Flame Retardant Non Category
Anti-termite

Anti-rodent
Oil Resistance
UV Resistance
Low Smoke Zero Halogen

IDENTIFICATIONS

Core Not Applicable

Others colours available upon request

IEC 60332-1 IEC 60332-3-22 IEC 60332-3-23 IEC 60332-3-24	Standard	Excellent	0°C	14 D	Pb	Normal Operation Temperature	Short Circuit Temperature

Dimension and Electrical Data

Cross Section	Tension U ₀ /U	Conductor Diameter	Insulation Diameter	Sep. Sheath Diameter	Metallic Screen Diameter	Outer Sheath Diameter	Cable Weight	Packaging	Max DC Resistance at 20°C	Current Rating in air at 20°C	Current Rating in ground at 20°C	Short Circuit Current for 1s
mm ²	kV	mm	mm	mm	mm	mm	kg/km	m	Ω/km	A	A	kA
1x50	3.6/6	8.2	16.2	21	25	28	2428	1000	0.387	238	196	7.2
1x70	3.6/6	9.8	16.8	22	26	29	2707	1000	0.268	296	239	10.0
1x95	3.6/6	11.3	18.3	23	27	31	3101	1000	0.193	361	285	13.6
1x120	3.6/6	12.8	19.8	24	29	32	3453	1000	0.153	417	323	17.2
1x150	3.6/6	14.2	21.6	26	30	34	3839	1000	0.124	473	361	21.5
1x185	3.6/6	15.7	23.1	27	32	35	4299	1000	0.0991	537	462	26.5
1x240	3.6/6	18.1	25.6	30	34	38	5065	500	0.0754	641	469	34.3
1x300	3.6/6	20.2	27.6	32	36	40	5796	500	0.0601	735	526	42.9
1x400	3.6/6	22.8	30.3	36	39	43	6776	500	0.047	845	590	57.2
1x500	3.6/6	26.1	33.6	39	42	47	8227	500	0.0366	961	668	71.5
1x630	3.6/6	29.9	37.5	43	46	51	10115	250	0.0283	1078	734	90.1
1x50	6/10	8.2	16.6	21	25	28	2473	1000	0.387	238	196	7.2
1x70	6/10	9.8	17.2	22	26	30	2765	1000	0.268	296	239	10.0
1x95	6/10	11.3	18.7	23	28	31	3147	1000	0.193	361	285	13.6
1x120	6/10	12.8	20.2	25	29	33	3514	1000	0.153	417	323	17.2
1x150	6/10	14.2	21.6	26	31	34	3886	1000	0.124	473	361	21.5
1x185	6/10	15.7	23.1	27	32	36	4363	1000	0.0991	543	406	26.5
1x240	6/10	18.1	25.5	30	35	39	5132	500	0.0754	641	469	34.3
1x300	6/10	20.2	27.6	32	37	41	5866	500	0.0601	735	526	42.9
1x400	6/10	22.8	30.2	35	40	44	7037	500	0.047	845	590	57.2
1x500	6/10	26.1	33.5	38	43	48	8436	500	0.0366	961	668	71.5
1x630	6/10	29.9	38.5	43	47	52	10342	250	0.0283	1078	734	90.1
1x50	8.7/15	8.2	18.7	24	27	31	2721	1000	0.387	238	196	7.2
1x70	8.7/15	9.8	19.3	24	28	32	3019	1000	0.268	296	239	10.0
1x95	8.7/15	11.3	21.4	26	30	34	3407	1000	0.193	361	285	13.6
1x120	8.7/15	12.8	22.3	27	31	35	3780	1000	0.153	407	366	17.2
1x150	8.7/15	14.2	23.7	28	33	37	4157	1000	0.124	473	361	21.5
1x185	8.7/15	15.7	25.2	30	34	38	4640	1000	0.0991	543	406	26.5
1x240	8.7/15	18.1	27.6	32	37	41	5419	500	0.0754	641	469	34.3
1x300	8.7/15	20.2	30.2	36	39	43	6142	500	0.0601	735	526	42.9
1x400	8.7/15	22.8	32.4	37	42	46	7351	500	0.047	845	590	57.2
1x500	8.7/15	26.1	35.7	40	45	50	8769	500	0.0366	961	668	71.5
1x630	8.7/15	29.9	40.0	45	49	54	10697	250	0.0283	1078	734	90.1

Dimension and Electrical Data (cont.)

Cross Section	Tension U ₀ /U	Conductor Diameter	Insulation Diameter	Sep. Sheath Diameter	Metallic Screen Diameter	Outer Sheath Diameter	Cable Weight	Packaging	Max DC Resistance at 20°C	Current Rating in air at 20°C	Current Rating in ground at 20°C	Short Circuit Current for 1s
mm ²	kV	mm	mm	mm	mm	mm	kg/km	m	Ω/km	A	A	kA
1x50	12/20	8.2	19.6	24	29	33	2955	1000	0.387	238	196	7.2
1x70	12/20	9.8	21.2	26	30	34	3242	1000	0.268	296	239	10.0
1x95	12/20	11.3	22.8	28	32	36	3651	1000	0.193	361	285	13.6
1x120	12/20	12.8	24.3	29	33	37	4013	1000	0.153	417	323	17.2
1x150	12/20	14.2	25.6	30	35	39	4411	1000	0.124	473	361	21.5
1x185	12/20	15.7	27.2	32	36	41	4901	1000	0.0991	543	406	26.5
1x240	12/20	18.1	29.6	34	39	43	5668	500	0.0754	641	469	34.3
1x300	12/20	20.2	31.7	37	41	45	6564	500	0.0601	735	526	42.9
1x400	12/20	22.8	34.3	39	44	49	7779	500	0.047	845	590	57.2
1x500	12/20	26.1	37.6	42	47	52	9225	500	0.0366	961	668	71.5
1x630	12/20	29.9	41.9	47	51	57	11212	250	0.0283	1078	734	90.1
1x50	18/30	8.2	24.5	29	34	38	3566	1000	0.387	238	1196	7.2
1x70	18/30	9.8	26.1	31	35	39	3862	1000	0.268	296	239	10.0
1x95	18/30	11.3	27.7	32	37	41	4416	1000	0.193	361	285	13.6
1x120	18/30	12.8	29.1	34	38	43	4796	1000	0.153	417	323	17.2
1x150	18/30	14.2	30.5	35	40	45	5355	500	0.124	473	361	21.5
1x185	18/30	15.7	32.0	37	42	46	5848	500	0.0991	543	406	26.5
1x240	18/30	18.1	34.4	39	44	49	6831	500	0.0754	641	469	34.3
1x300	18/30	20.2	36.6	41	47	52	7954	500	0.0601	735	526	42.9
1x400	18/30	22.8	39.2	44	50	55	9250	500	0.047	845	590	57.2
1x500	18/30	26.1	42.5	47	53	58	10600	250	0.0366	961	668	71.5
1x630	18/30	29.9	47.4	52	57	62	12682	250	0.0283	1078	734	90.1

Copper Cable - Lead Sheath XLPE Insulation

3.6/6(7.2) - 18/30(36) kV

3C CU/XLPE/CTS/PVC/LS/PVC – N2XSEKY



CONSTRUCTION

Conductor	: Plain annealed copper wire according to IEC 60228 - Class 2 for Stranded Compacted Conductors
Conductor Screen	: Extruded Semi Conductive Compound
Insulation	: XLPE Compound
Insulation Screen	: Extruded Semi Conductive Compound
Metallic Screen	: Plain Annealed Copper Tapes
Filler	: PP Yarn Filler
Metallic Sheath	: Lead Alloy Sheath
Sheath	: PVC ST2 Compound

APPLICABLE STANDARDS

SNI IEC 60502-2, IEC 60502-2
IEC 60228
IEC 60332-1
IEC 60332-3-22
IEC 60332-3-23
IEC 60332-3-24

Design and Test Guidelines
Conductor
Flame Retardant
Flame Retardant Cat. A
Flame Retardant Cat. B
Flame Retardant Cat. C

Special features on request:
EPR Insulation
Flame Retardant Cat. A, B, C
Flame Retardant Non Category
Anti-termite

Anti-rodent
Oil Resistance
UV Resistance
Low Smoke Zero Halogen

IDENTIFICATIONS

Core Brown, Black, Grey

Others colours available upon request



IEC 60332-1
IEC 60332-3-22
IEC 60332-3-23
IEC 60332-3-24



Standard



Excellent



0°C



14 D



90°C
Normal
Operation
Temperature



250°C
Short
Circuit
Temperature

Dimension and Electrical Data

Cross Section	Tension U ₀ /U	Conductor Diameter	Insulation Diameter	Metallic Screen Diameter	Outer Sheath Diameter	Cable Weight	Packaging	Max DC Resistance at 20°C	Current Rating in air at 20°C	Current Rating in ground at 20°C	Short Circuit Current for 1s
mm ²	kV	mm	mm	mm	mm	kg/km	m	Ω/km	A	A	kA
3x50	3.6/6	8.2	16	42	47	5241	500	0.3870	205	181	7.2
3x70	3.6/6	9.8	17	45	49	6212	500	0.2680	253	220	10.0
3x95	3.6/6	11.4	19	48	53	7521	500	0.1930	307	263	13.6
3x120	3.6/6	12.9	21	52	57	8753	500	0.1530	352	298	17.2
3x150	3.6/6	14.3	22	55	60	10076	250	0.1240	397	332	21.5
3x185	3.6/6	15.8	23	59	64	11901	250	0.0991	453	374	26.5
3x240	3.6/6	18.3	26	64	70	14485	250	0.0754	529	431	34.3
3x300	3.6/6	20.4	28	69	76	17252	250	0.0601	599	482	42.9
3x50	6/10	8.2	17	43	48	5528	500	0.3870	205	181	7.2
3x70	6/10	9.8	18	46	51	6539	500	0.2680	253	220	10.0
3x95	6/10	11.4	19	49	55	7847	500	0.1930	307	253	13.6
3x120	6/10	12.9	21	53	58	9100	500	0.1530	352	298	17.2
3x150	6/10	14.3	22	56	62	10643	250	0.1240	397	332	21.5
3x185	6/10	15.8	24	60	66	12323	250	0.0991	453	374	26.5
3x240	6/10	18.3	26	65	71	14909	250	0.0754	529	431	34.3
3x300	6/10	20.4	28	70	77	17707	250	0.0601	599	482	42.9
3x50	8.7/15	8.2	19	48	53	6550	500	0.3870	205	181	7.2
3x70	8.7/15	9.8	20	51	56	7617	500	0.2680	253	220	10.0
3x95	8.7/15	11.4	22	55	60	9188	500	0.1930	307	263	13.6
3x120	8.7/15	12.9	23	58	64	10518	250	0.1530	352	298	17.2
3x150	8.7/15	14.3	24	61	67	11716	250	0.1240	397	332	21.5
3x185	8.7/15	15.8	26	65	71	13419	250	0.0991	453	374	26.5
3x240	8.7/15	18.3	28	70	77	16362	250	0.0754	529	431	34.3
3x300	8.7/15	20.4	31	75	82	18999	250	0.0601	599	482	42.9

Dimension and Electrical Data (cont.)

Cross Section	Tension U _o /U	Conductor Diameter	Insulation Diameter	Metallic Screen Diameter	Outer Sheath Diameter	Cable Weight	Packaging	Max DC Resistance at 20°C	Current Rating in air at 20°C	Current Rating in ground at 20°C	Short Circuit Current for 1s
mm ²	kV	mm	mm	mm	mm	kg/km	m	Ω/km	A	A	kA
3x50	12/20	8.2	21	53	58	7420	500	0.387	205	181	7.2
3x70	12/20	9.8	22	55	61	8700	500	0.268	253	220	10.0
3x95	12/20	11.4	24	59	65	10138	250	0.193	307	253	13.6
3x120	12/20	12.9	25	62	69	11548	250	0.153	352	298	17.2
3x150	12/20	14.3	26	66	72	13011	250	0.124	397	332	21.5
3x185	12/20	15.8	28	69	76	14779	250	0.0991	453	374	26.5
3x240	12/20	18.3	30	75	82	17562	250	0.0754	529	431	34.3
3x300	12/20	20.4	33	79	87	20224	250	0.0601	599	482	42.9
3x50	18/30	8.2	26	64	70	10405	250	0.387	205	181	7.2
3x70	18/30	9.8	27	67	73	11613	250	0.268	253	220	10.0
3x95	18/30	11.4	28	70	77	13199	250	0.193	307	263	13.6
3x120	18/30	12.9	30	74	81	14755	250	0.153	352	298	17.2
3x150	18/30	14.3	31	77	84	16351	250	0.124	397	332	21.5
3x185	18/30	15.8	33	81	88	18262	250	0.0991	453	374	26.5
3x240	18/30	18.3	35	86	94	21559	250	0.0754	529	431	34.3
3x300	18/30	20.4	37	91	99	24419	250	0.0601	599	482	42.9

Copper Cable - Lead Sheath XLPE Insulation

3.6/6(7.2) - 18/30(36) kV

1C CU/XLPE/CTS/LS/PVC/DATA/PVC – N2XSKB(AL)Y

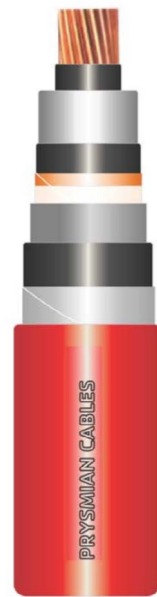

CONSTRUCTION

Conductor	: Plain annealed copper wire according to IEC 60228 - Class 2 for Stranded Compacted Conductors
Conductor Screen	: Extruded Semi Conductive Compound
Insulation	: XLPE Compound
Insulation Screen	: Extruded Semi Conductive Compound
Metallic Screen	: Plain Annealed Copper Tapes
Metallic Sheath	: Lead Alloy Sheath
Separation Sheath	: PVC Compound ST 2
Metallic Armour	: Double Aluminium Tapes
Sheath	: PVC Compound ST 2

APPLICABLE STANDARDS

SNI IEC 60502-2, IEC 60502-2
IEC 60228
IEC 60332-1
IEC 60332-3-22
IEC 60332-3-23
IEC 60332-3-24

Design and Test Guidelines
Conductor
Flame Retardant
Flame Retardant Cat. A
Flame Retardant Cat. B
Flame Retardant Cat. C

Special features on request:
EPR Insulation
Flame Retardant Cat. A, B, C
Flame Retardant Non Category
Anti-termite

Anti-rodent
Oil Resistance
UV Resistance
Low Smoke Zero Halogen

IDENTIFICATIONS

Core Not Applicable



IEC 60332-1
IEC 60332-3-22
IEC 60332-3-23
IEC 60332-3-24



Standard



Excellent



0°C



14 D



90°C
Normal Operation Temperature



250°C
Short Circuit Temperature

Dimension and Electrical Data

Cross Section	Tension U ₀ /U	Conductor Diameter	Insulation Diameter	Metallc Sheath Diameter	Sep. Sheath Diameter	Armour Diameter	Outer Sheath Diameter	Cable Weight	Packaging	Max DC Resistance at 20°C	Current Rating in air at 30°C	Current Rating in ground at 20°C	Short Circuit Current for 1s
mm ²	kV	mm	mm	mm	mm	mm	mm	kg/km	m	Ω/km	A	A	kA
1x50	3.6/6	8.2	16	22	25	28	31	2473	1000	0.387	238	196	7.2
1x70	3.6/6	9.8	17	23	26	29	32	2774	1000	0.268	296	239	10.0
1x95	3.6/6	11.4	19	25	28	30	34	3182	1000	0.193	361	285	13.6
1x120	3.6/6	12.9	21	26	29	32	35	3544	1000	0.153	417	323	17.2
1x150	3.6/6	14.3	22	28	31	33	37	3943	1000	0.124	473	361	21.5
1x185	3.6/6	15.8	23	29	32	35	38	4414	1000	0.099	543	462	26.5
1x240	3.6/6	18.3	26	31	35	37	41	5199	500	0.015	641	469	34.3
1x300	3.6/6	20.4	28	34	37	39	43	5948	500	0.060	735	526	42.9
1x400	3.6/6	23.0	30	36	39	41	46	6948	500	0.0470	845	590	57.2
1x500	3.6/6	26.4	34	40	43	45	so	8420	500	0.0366	961	668	71.5
1x630	3.6/6	30.2	38	44	47	49	54	10331	250	0.0283	1078	734	90.1
1x50	6/10	8.2	17	22	25	28	31	2536	1000	0.387	238	196	7.2
1x70	6/10	9.8	18	23	26	29	33	2839	1000	0.268	296	239	10.0
1x95	6/10	11.4	19	25	28	31	34	3232	1000	0.193	361	285	13.6
1x120	6/10	12.9	21	27	30	32	36	3612	1000	0.153	417	323	17.2
1x150	6/10	14.3	22	28	31	33	37	3995	1000	0.124	473	361	21.5
1x185	6/10	15.8	24	29	32	35	39	4485	1000	0.099	543	406	26.5
1x240	6/10	18.3	26	32	35	37	42	5272	500	0.075	641	469	34.3
1x300	6/10	20.4	28	34	37	40	44	6023	500	0.060	735	526	42.9
1x400	6/10	23.0	31	37	40	42	47	7076	500	0.0470	845	590	57.2
1x500	6/10	26.4	34	40	43	46	50	8479	500	0.0366	961	668	71.5
1x630	6/10	30.2	38	44	47	50	55	10393	250	0.0283	1078	734	90.1
1x50	8.7/15	8.2	19	25	28	30	34	2802	1000	0.387	238	196	7.2
1x70	8.7/15	9.8	20	26	29	31	35	3095	1000	0.268	296	239	10.0
1x95	8.7/15	11.4	22	27	30	33	37	3509	1000	0.193	361	285	13.6
1x120	8.7/15	12.9	23	29	32	34	38	3895	1000	0.153	417	366	17.2
1x150	8.7/15	14.3	24	30	33	36	40	4283	1000	0.124	473	361	21.5
1x185	8.7/15	15.8	26	32	35	37	41	4779	1000	0.099	543	406	26.5
1x240	8.7/15	18.3	28	34	37	40	44	5576	500	0.075	641	469	34.3
1x300	8.7/15	20.4	31	36	39	42	46	6315	500	0.060	735	526	42.9
1x400	8.7/15	23	33	39	42	45	49	7541	500	0.0470	845	590	57.2
1x500	8.7/15	26.4	36	42	45	48	53	8975	500	0.0366	961	668	71.5
1x630	8.7/15	30.2	40	46	49	52	57	10926	250	0.0283	1078	734	90.1

Dimension and Electrical Data (cont.)

Cross Section	Tension U _o /U	Conductor Diameter	Insulation Diameter	Metallic Sheath Diameter	Sep. Sheath Diameter	Armour Diameter	Outer Sheath Diameter	Cable Weight	Packaging	Max DC Resistance at 20°C	Current Rating in air at 30°C	Current Rating in ground at 20°C	Short Circuit Current for 1s
mm ²	kV	mm	mm	mm	mm	mm	mm	kg/km	m	Ω/km	A	A	kA
1x50	12/20	8.2	21	26	30	32	36	3053	1000	0.387	238	196	7.2
1x70	12/20	9.8	22	28	31	33	37	3349	1000	0.268	296	239	10.0
1x95	12/20	11.4	24	29	32	35	39	3769	1000	0.193	361	285	13.6
1x120	12/20	12.9	25	31	34	36	40	4143	1000	0.153	417	323	17.2
1x150	12/20	14.3	26	32	35	38	42	4553	1000	0.124	473	361	21.5
1x185	12/20	15.8	28	34	37	39	44	5055	500	0.099	543	462	26.5
1x240	12/20	18.3	30	36	39	42	46	5841	500	0.075	641	469	34.3
1x300	12/20	20.4	33	38	41	44	48	6607	500	0.060	735	526	42.9
1x400	12/20	23.0	35	41	44	47	51	7827	500	0.0470	845	590	57.2
1x500	12/20	26.4	38	44	47	50	55	9278	500	0.0366	961	668	71.5
1x630	12/20	30.2	42	48	51	54	59	11274	250	0.0283	1078	734	90.1
1x50	18/30	8.2	26	31	34	37	41	3703	1000	0.387	238	196	7.2
1x70	18/30	9.8	27	32	36	38	42	4007	1000	0.268	296	239	10.0
1x95	18/30	11.4	28	34	37	40	44	4443	1000	0.193	361	285	13.6
1x120	18/30	12.9	30	36	39	41	46	4958	1000	0.153	417	323	17.2
1x150	18/30	14.3	31	37	40	43	47	5387	500	0.124	473	361	21.5
1x185	18/30	15.8	33	39	42	44	49	6050	500	0.099	543	406	26.5
1x240	18/30	18.3	35	41	44	47	52	6872	500	0.075	641	469	34.3
1x300	18/30	20.4	37	44	47	49	54	7830	500	0.060	735	526	42.9
1x400	18/30	23.0	40	47	50	52	58	9316	500	0.0470	845	590	57.2
1x500	18/30	26.4	43	50	53	56	61	10859	250	0.0366	961	668	71.5
1x630	18/30	30.2	47	54	57	60	65	12938	250	0.0283	1078	734	90.1

Copper Cable - Lead Sheath XLPE Insulation

3.6/6(7.2) - 18/30(36) kV

3C CU/XLPE/CTS/LS/PVC/DSTA/PVC – N2XSEKBY

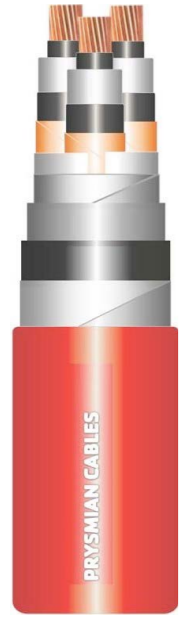

CONSTRUCTION

Conductor	: Plain annealed copper wire according to IEC 60228 - Class 2 for Stranded Compacted Conductors
Conductor Screen	: Extruded Semi Conductive Compound
Insulation	: XLPE Compound
Insulation Screen	: Extruded Semi Conductive Compound
Metallic Screen	: Plain Annealed Copper Tapes
Filler	: PP Yarn Filler
Metallic Sheath	: Lead Alloy Sheath
Separation Sheath	: PVC ST2 Compound
Metallic Armour	: Double Galvanized Steel Tapes
Sheath	: PVC ST2 Compound

APPLICABLE STANDARDS

SNI IEC 60502-2, IEC 60502-2
IEC 60228
IEC 60332-1
IEC 60332-3-22
IEC 60332-3-23
IEC 60332-3-24

Design and Test Guidelines
Conductor
Flame Retardant
Flame Retardant Cat. A
Flame Retardant Cat. B
Flame Retardant Cat. C

Special features on request:
EPR Insulation
Flame Retardant Cat. A, B, C
Flame Retardant Non Category
Anti-termite

Anti-rodent
Oil Resistance
UV Resistance
Low Smoke Zero Halogen

IDENTIFICATIONS

Core Brown, Black, Grey

Others colours available upon request



IEC 60332-1
IEC 60332-3-22
IEC 60332-3-23
IEC 60332-3-24



Standard



Excellent



0°C



14 D



90°C
Normal
Operation
Temperature



250°C
Short
Circuit
Temperature

Dimension and Electrical Data

Cross Section	Tension U ₀ /U	Conductor Diameter	Insulation Diameter	Metallic Sheath Diameter	Sep. Sheath Diameter	Armour Diameter	Outer Sheath Diameter	Cable Weight	Packaging	Max DC Resistance at 20°C	Current Rating in air at 30°C	Current Rating in ground at 20°C	Short Circuit Current for 1s
mm ²	kV	mm	mm	mm	mm	mm	mm	kg/km	m	Ω/km	A	A	kA
3x50	3.6/6	8.2	16	42	45	47	52	6364	500	0.387	205	181	7.2
3x70	3.6/6	9.8	17	45	48	50	55	7400	500	0.268	253	220	10.0
3x95	3.6/6	11.4	19	48	51	54	59	8771	500	0.193	307	263	13.6
3x120	3.6/6	12.9	21	52	55	57	63	10112	250	0.153	352	298	17.2
3x150	3.6/6	14.3	22	55	58	60	66	11513	250	0.124	397	332	21.5
3x185	3.6/6	15.8	23	58	61	64	70	13427	250	0.0991	453	374	26.5
3x240	3.6/6	18.3	26	64	67	69	76	16141	250	0.0754	529	431	34.3
3x300	3.6/6	20.4	28	69	72	76	83	19771	250	0.0601	599	482	42.9
3x50	6/10	8.2	17	43	46	49	54	6680	500	0.387	205	181	7.2
3x70	6/10	9.8	18	46	49	51	57	7757	500	0.268	253	220	10.0
3x95	6/10	11.4	19	49	52	55	60	9153	500	0.193	307	263	13.6
3x120	6/10	12.9	21	53	56	58	64	10487	250	0.153	352	298	17.2
3x150	6/10	14.3	22	56	59	62	68	12111	250	0.124	397	332	21.5
3x185	6/10	15.8	24	59	63	65	71	13846	250	0.0991	453	374	26.5
3x240	6/10	18.3	26	65	68	72	79	17330	250	0.0754	529	431	34.3
3x300	6/10	20.4	28	70	73	77	84	20265	250	0.0601	599	482	42.9
3x50	8.7/15	8.2	19	48	51	54	59	7846	500	0.387	205	181	7.2
3x70	8.7/15	9.8	20	51	54	56	62	8951	500	0.268	253	220	10.0
3x95	8.7/15	11.4	22	54	58	60	66	10642	250	0.193	307	263	13.6
3x120	8.7/15	12.9	23	58	61	64	70	12057	250	0.153	352	298	17.2
3x150	8.7/15	14.3	24	61	64	67	73	13327	250	0.124	397	332	21.5
3x185	8.7/15	15.8	26	64	68	72	78	15849	250	0.0991	453	374	26.5
3x240	8.7/15	18.3	28	70	73	77	85	18990	250	0.0754	529	431	34.3
3x300	8.7/15	20.4	31	75	78	82	89	21752	250	0.0601	599	482	42.9

Dimension and Electrical Data (cont.)

Cross Section	Tension U ₀ /U	Conductor Diameter	Insulation Diameter	Metallic Sheath Diameter	Sep. Sheath Diameter	Armour Diameter	Outer Sheath Diameter	Cable Weight	Packaging	Max DC Resistance at 20°C	Current Rating in air at 30°C	Current Rating in ground at 20°C	Short Circuit Current for 1s
mm ²	kV	mm	mm	mm	mm	mm	mm	kg/km	m	Ω/km	A	A	kA
3x50	12/20	8.2	21	52	56	58	64	8826	500	0.387	205	181	7.2
3x70	12/20	9.8	22	55	58	61	67	10173	250	0.268	253	220	10.0
3x95	12/20	11.4	24	59	62	65	71	11703	250	0.193	307	263	13.6
3x120	12/20	12.9	25	62	65	68	75	13197	250	0.153	352	298	17.2
3x150	12/20	14.3	26	65	69	73	80	15444	250	0.124	397	332	21.5
3x185	12/20	15.8	28	69	72	76	83	17331	250	0.0991	453	374	26.5
3x240	12/20	18.3	30	74	78	82	89	20304	250	0.0754	529	431	34.3
3x300	12/20	20.4	33	79	82	86	94	23171	200	0.0601	599	482	42.9
3x50	18/30	8.2	26	64	67	70	76	12094	250	0.387	205	181	7.2
3x70	18/30	9.8	27	67	70	74	81	14124	250	0.268	307	220	10.0
3x95	18/30	11.4	28	70	73	77	85	15834	250	0.193	352	263	13.6
3x120	18/30	12.9	30	74	77	81	88	17472	250	0.153	397	298	17.2
3x150	18/30	14.3	31	77	80	84	92	19175	250	0.124	453	332	21.5
3x185	18/30	15.8	33	80	84	88	96	21249	250	0.0991	529	374	26.5
3x240	18/30	18.3	35	86	89	93	102	24745	200	0.0754	599	431	34.3
3x300	18/30	20.4	37	91	94	98	107	27767	200	0.0601	205	482	42.9

Copper Cable - Lead Sheath XLPE Insulation

3.6/6(7.2) - 18/30(36) kV

1C CU/XLPE/CTS/LS/PVC/AWA/PVC – N2XSKYR(AL)Y



CONSTRUCTION

Conductor	: Plain annealed copper wire according to IEC 60228 - Class 2 for Stranded Compacted Conductors
Conductor Screen	: Extruded Semi Conductive Compound
Insulation	: XLPE Compound
Insulation Screen	: Extruded Semi Conductive Compound
Metallic Screen	: Plain Annealed Copper Tapes
Metallic Sheath	: Lead Alloy Sheath
Separation Sheath	: PVC Compound ST 2
Metallic Armour	: Aluminium Wires
Sheath	: PVC Compound ST 2

APPLICABLE STANDARDS

SNI IEC 60502-2, IEC 60502-2
IEC 60228
IEC 60332-1
IEC 60332-3-22
IEC 60332-3-23
IEC 60332-3-24

Design and Test Guidelines
Conductor
Flame Retardant
Flame Retardant Cat. A
Flame Retardant Cat. B
Flame Retardant Cat. C

Special features on request:
EPR Insulation
Flame Retardant Cat. A, B, C
Flame Retardant Non Category
Anti-termite

Anti-rodent
Oil Resistance
UV Resistance
Low Smoke Zero Halogen

IDENTIFICATIONS

Core Not Applicable



IEC 60332-1
IEC 60332-3-22
IEC 60332-3-23
IEC 60332-3-24



Standard



Excellent



0°C



14 D



90°C
Normal
Operation
Temperature



250°C
Short
Circuit
Temperature

Dimension and Electrical Data

Cross Section	Tension U ₀ /U	Conductor Diameter	Insulation Diameter	Metallc Sheath Diameter	Sep. Sheath Diameter	Armour Diameter	Outer Sheath Diameter	Cable Weight	Packaging	Max DC Resistance at 20°C	Current Rating in air at 30°C	Current Rating in ground at 20°C	Short Circuit Current for 1s
mm ²	kV	mm	mm	mm	mm	mm	mm	kg/km	m	Ω/km	A	A	kA
1x50	3.6/6	8.2	16	22	25	28	32	2648	1000	0.387	238	196	7.2
1x70	3.6/6	9.8	17	23	26	30	34	2936	1000	0.268	296	239	10.0
1x95	3.6/6	11.4	19	25	28	32	36	3440	1000	0.193	361	285	13.6
1x120	3.6/6	12.9	21	26	29	33	38	3830	1000	0.153	417	323	17.2
1x150	3.6/6	14.3	22	28	31	35	39	4224	1000	0.124	473	361	21.5
1x185	3.6/6	15.8	23	29	32	36	41	4725	1000	0.099	543	406	26.5
1x240	3.6/6	18.3	26	32	35	39	44	5527	500	0.075	641	469	34.3
1x300	3.6/6	20.4	28	34	37	42	47	6430	500	0.060	735	526	42.9
1x400	3.6/6	23.0	30	36	39	44	49	7452	500	0.0470	845	590	57.2
1x500	3.6/6	26.4	34	40	43	48	53	8967	500	0.0366	961	668	71.5
1x630	3.6/6	30.2	38	44	47	52	58	10932	250	0.0283	1078	734	90.1
1x50	6/10	8.2	17	23	26	29	33	2696	1000	0.387	238	196	7.2
1x70	6/10	9.8	18	24	27	31	35	3087	1000	0.268	296	239	10.0
1x95	6/10	11.4	19	25	28	32	37	3507	1000	0.193	361	285	13.6
1x120	6/10	12.9	21	27	30	34	38	3881	1000	0.153	417	323	17.2
1x150	6/10	14.3	22	28	31	35	40	4295	1000	0.124	473	361	21.5
1x185	6/10	15.8	24	30	33	37	42	4797	1000	0.099	543	406	26.5
1x240	6/10	18.3	26	32	35	39	44	5580	500	0.075	641	469	34.3
1x300	6/10	20.4	28	34	37	42	48	6507	500	0.060	735	526	42.9
1x400	6/10	23.0	31	37	40	45	50	7592	500	0.0470	845	590	57.2
1x500	6/10	26.4	34	40	43	48	54	9038	500	0.0366	961	668	71.5
1x630	6/10	30.2	38	44	47	52	58	10993	250	0.0283	1078	734	90.1
1x50	8.7/15	8.2	19	25	28	32	36	3070	1000	0.387	238	196	7.2
1x70	8.7/15	9.8	20	26	29	33	37	3376	1000	0.268	296	239	10.0
1x95	8.7/15	11.4	22	27	30	34	39	3802	1000	0.193	361	285	13.6
1x120	8.7/15	12.9	23	29	32	36	41	4182	1000	0.153	417	323	17.2
1x150	8.7/15	14.3	24	30	33	37	42	4601	1000	0.124	473	361	21.5
1x185	8.7/15	15.8	26	32	35	39	44	5090	500	0.099	543	406	26.5
1x240	8.7/15	18.3	28	34	37	42	48	6059	500	0.075	641	469	34.3
1x300	8.7/15	20.4	31	36	39	44	so	6831	500	0.060	735	526	42.9
1x400	8.7/15	23.0	33	39	42	47	53	8091	500	0.0470	845	590	57.2
1x500	8.7/15	26.4	36	43	46	51	56	9554	500	0.0366	961	668	71.5
1x630	8.7/15	30.2	40	47	50	55	61	11559	250	0.0283	1078	734	90.1

Dimension and Electrical Data (cont.)

Cross Section	Tension U ₀ /U	Conductor Diameter	Insulation Diameter	Metallic Sheath Diameter	Sep. Sheath Diameter	Armour Diameter	Outer Sheath Diameter	Cable Weight	Packaging	Max DC Resistance at 20°C	Current Rating in air at 30°C	Current Rating in ground at 20°C	Short Circuit Current for 1s
mm ²	kV	mm	mm	mm	mm	mm	mm	kg/km	m	Ω/km	A	A	kA
1x50	12/20	8.2	21	27	30	34	38	3323	1000	0.387	238	196	7.2
1x70	12/20	9.8	22	28	31	35	40	3650	1000	0.268	296	239	10.0
1x95	12/20	11.4	24	29	32	36	41	4083	1000	0.193	361	285	13.6
1x120	12/20	12.9	25	31	34	38	43	4467	1000	0.153	417	323	17.2
1x150	12/20	14.3	26	32	35	40	45	5017	500	0.124	473	361	21.5
1x185	12/20	15.8	28	34	37	42	47	5542	500	0.099	543	406	26.5
1x240	12/20	18.3	30	36	39	44	so	6343	500	0.075	641	469	34.3
1x300	12/20	20.4	33	38	41	46	52	7144	500	0.060	735	526	42.9
1x400	12/20	23.0	35	41	44	49	55	8398	500	0.0470	845	590	57.2
1x500	12/20	26.4	38	45	48	53	58	9877	500	0.0366	961	668	71.5
1x630	12/20	30.2	42	49	52	57	63	11928	250	0.0283	1078	734	90.1
1x50	18/30	8.2	26	32	35	39	44	4015	1000	0.387	238	196	7.2
1x70	18/30	9.8	27	33	36	41	46	4483	1000	0.268	296	239	10.0
1x95	18/30	11.4	28	34	37	42	48	4927	1000	0.193	361	285	13.6
1x120	18/30	12.9	30	36	39	44	49	5462	500	0.153	417	323	17.2
1x150	18/30	14.3	31	37	40	45	51	5916	500	0.124	473	361	21.5
1x185	18/30	15.8	33	39	42	47	53	6601	500	0.099	543	406	26.5
1x240	18/30	18.3	35	42	45	50	55	7440	500	0.075	641	469	34.3
1x300	18/30	20.4	37	44	47	52	58	8432	500	0.060	735	526	42.9
1x400	18/30	23.0	40	47	50	55	61	9951	500	0.0470	845	590	57.2
1x500	18/30	26.4	43	50	53	58	65	11538	250	0.0366	961	668	71.5
1x630	18/30	30.2	47	54	57	62	69	13657	250	0.0283	1078	734	90.1

Copper Cable - Lead Sheath XLPE Insulation

3.6/6(7.2) - 18/30(36) kV

3C CU/XLPE/CTS/LS/PVC/SWA/PVC – N2XSEKRY



CONSTRUCTION

Conductor	: Plain annealed copper wire according to IEC 60228 - Class 2 for Stranded Compacted Conductors
Conductor Screen	: Extruded Semi Conductive Compound
Insulation	: XLPE Compound
Insulation Screen	: Extruded Semi Conductive Compound
Metallic Screen	: Plain Annealed Copper Tapes
Filler	: PP Yarn Filler
Metallic Sheath	: Lead Alloy Sheath
Separation Sheath	: PVC ST2 Compound
Metallic Armour	: Galvanized Steel Wires
Sheath	: PVC ST2 Compound

APPLICABLE STANDARDS

SNI IEC 60502-2, IEC 60502-2
IEC 60228
IEC 60332-1
IEC 60332-3-22
IEC 60332-3-23
IEC 60332-3-24

Special features on request:
EPR Insulation
Flame Retardant Cat. A, B, C
Flame Retardant Non Category
Anti-termite

Design and Test Guidelines
Conductor
Flame Retardant
Flame Retardant Cat. A
Flame Retardant Cat. B
Flame Retardant Cat. C

Anti-rodent
Oil Resistance
UV Resistance
Low Smoke Zero Halogen

IDENTIFICATIONS

Core Brown, Black, Grey

Others colours available upon request



IEC 60332-1
IEC 60332-3-22
IEC 60332-3-23
IEC 60332-3-24



Standard



Excellent



0°C



14 D



Normal
Operation
Temperature



Short
Circuit
Temperature

Dimension and Electrical Data

Cross Section	Tension U ₀ /U	Conductor Diameter	Insulation Diameter	Metallic Sheath Diameter	Sep. Sheath Diameter	Armour Diameter	Outer Sheath Diameter	Cable Weight	Packaging	Max DC Resistance at 20°C	Current Rating in air at 30°C	Current Rating in ground at 20°C	Short Circuit Current for 1s
mm ²	kV	mm	mm	mm	mm	mm	mm	kg/km	m	Ω/km	A	A	kA
3x50	3.6/6	8.2	16	42	45	50	56	781.4	500	0.387	205	181	7.2
3x70	3.6/6	9.8	17	45	48	53	59	893.3	500	0.268	253	220	10.0
3x95	3.6/6	11.4	19	48	52	57	63	1044.2	250	0.193	307	263	13.6
3x120	3.6/6	12.9	21	52	55	60	66	1186.7	250	0.153	352	298	17.2
3x150	3.6/6	14.3	22	55	58	63	70	1334.3	250	0.124	397	332	21.5
3x185	3.6/6	15.8	23	59	62	68	75	1617.0	250	0.0991	453	374	26.5
3x240	3.6/6	18.3	26	64	67	74	81	1913.0	250	0.0754	529	431	34.3
3x300	3.6/6	20.4	28	69	72	79	87	2220.7	200	0.0601	599	482	42.9
3x50	6/10	8.2	17	43	46	51	57	818.5	500	0.387	205	181	7.2
3x70	6/10	9.8	18	46	49	54	60	932.2	500	0.268	253	220	10.0
3x95	6/10	11.4	19	49	53	58	64	1082.6	250	0.193	307	263	13.6
3x120	6/10	12.9	21	53	56	61	68	1230.3	250	0.153	352	298	17.2
3x150	6/10	14.3	22	56	59	66	73	1476.7	250	0.124	397	332	21.5
3x185	6/10	15.8	24	60	63	69	77	1664.4	250	0.0991	453	374	26.5
3x240	6/10	18.3	26	65	68	75	82	1963.5	250	0.0754	529	431	34.3
3x300	6/10	20.4	28	70	73	80	88	2274.3	200	0.0601	599	482	42.9
3x50	8.7/15	8.2	19	48	51	57	63	950.2	500	0.387	205	181	7.2
3x70	8.7/15	9.8	20	51	54	59	66	1069.2	250	0.268	253	220	10.0
3x95	8.7/15	11.4	22	55	58	64	71	1323.4	250	0.193	307	263	13.6
3x120	8.7/15	12.9	23	58	61	68	75	1479.0	250	0.153	352	298	17.2
3x150	8.7/15	14.3	24	61	64	71	78	1614.7	250	0.124	397	332	21.5
3x185	8.7/15	15.8	26	65	68	74	82	1807.9	250	0.0991	453	374	26.5
3x240	8.7/15	18.3	28	70	73	80	88	2139.9	250	0.0754	529	431	34.3
3x300	8.7/15	20.4	31	75	78	85	93	2434.1	200	0.0601	599	482	42.9

Dimension and Electrical Data (cont.)

Cross Section	Tension U ₀ /U	Conductor Diameter	Insulation Diameter	Metallic Sheath Diameter	Sep. Sheath Diameter	Armour Diameter	Outer Sheath Diameter	Cable Weight	Packaging	Max DC Resistance at 20°C	Current Rating in air at 30°C	Current Rating in ground at 20°C	Short Circuit Current for 1s
mm ²	kV	mm	mm	mm	mm	mm	mm	kg/km	m	Ω/km	A	A	kA
3x50	12/20	8.2	21	53	56	61	68	10590	250	0.387	205	181	7.2
3x70	12/20	9.8	22	56	59	65	72	12753	250	0.268	253	220	10.0
3x95	12/20	11.4	24	59	62	69	76	14485	250	0.193	307	263	13.6
3x120	12/20	12.9	25	63	66	72	80	16061	250	0.153	352	298	17.2
3x150	12/20	14.3	26	66	69	75	83	17747	250	0.124	397	332	21.5
3x185	12/20	15.8	28	69	72	79	87	19742	250	0.0991	453	374	26.5
3x240	12/20	18.3	30	75	78	84	93	22902	200	0.0754	529	431	34.3
3x300	12/20	20.4	33	80	83	89	98	25864	200	0.0601	599	482	42.9
3x50	18/30	8.2	26	64	67	74	81	15061	250	0.387	205	181	7.2
3x70	18/30	9.8	27	67	70	76	84	16426	250	0.268	253	220	10.0
3x95	18/30	11.4	28	71	74	80	88	18280	250	0.193	307	263	13.6
3x120	18/30	12.9	30	74	77	83	92	20026	250	0.153	352	298	17.2
3x150	18/30	14.3	31	77	80	87	95	21845	250	0.124	397	332	21.5
3x185	18/30	15.8	33	81	84	90	99	23982	200	0.0991	453	374	26.5
3x240	18/30	18.3	35	86	89	96	105	27658	200	0.0754	529	431	34.3
3x300	18/30	20.4	37	91	94	101	110	30867	200	0.0601	599	482	42.9

Copper Cable - Lead Sheath XLPE Insulation

3.6/6(7.2) - 18/30(36) kV

3C CU/XLPE/CTS/LS/PVC/SFA/PVC – N2XSEKFY

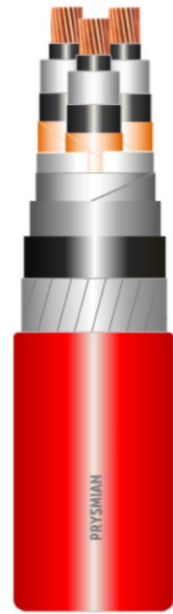

CONSTRUCTION

Conductor	: Plain annealed copper wire according to IEC 60228 - Class 2 for Stranded Compacted Conductors
Conductor Screen	: Extruded Semi Conductive Compound
Insulation	: XLPE Compound
Insulation Screen	: Extruded Semi Conductive Compound
Metallic Screen	: Plain Annealed Copper Tapes
Filler	: PP Yarn Filler
Metallic Sheath	: Lead Alloy Sheath
Separation Sheath	: PVC ST2 Compound
Metallic Armour	: Galvanized Steel Flat Armour
Sheath	: PVC ST2 Compound

APPLICABLE STANDARDS

SNI IEC 60502-2, IEC 60502-2
IEC 60228
IEC 60332-1
IEC 60332-3-22
IEC 60332-3-23
IEC 60332-3-24

Special features on request:
EPR Insulation
Flame Retardant Cat. A, B, C
Flame Retardant Non Category
Anti-termites

Design and Test Guidelines
Conductor
Flame Retardant
Flame Retardant Cat. A
Flame Retardant Cat. B
Flame Retardant Cat. C

Anti-rodent
Oil Resistance
UV Resistance
Low Smoke Zero Halogen

IDENTIFICATIONS

Core Brown, Black, Grey

Others colours available upon request



IEC 60332-1
IEC 60332-3-22
IEC 60332-3-23
IEC 60332-3-24



Standard



Excellent



0°C



14 D



90°C
Normal
Operation
Temperature



250°C
Short
Circuit
Temperature

Dimension and Electrical Data

Cross Section	Tension U ₀ /U	Conductor Diameter	Insulation Diameter	Metallic Sheath Diameter	Sep. Sheath Diameter	Armour Diameter	Outer Sheath Diameter	Cable Weight	Packaging	Max DC Resistance at 20°C	Current Rating in air at 30°C	Current Rating in ground at 20°C	Short Circuit Current for 1s
mm ²	kV	mm	mm	mm	mm	mm	mm	kg/km	m	Ω/km	A	A	kA
3x50	3.6/6	8.2	16	42	45	47	52	6478	500	0.387	205	181	7.2
3x70	3.6/6	9.8	17	45	48	50	55	7527	500	0.268	253	220	10.0
3x95	3.6/6	11.4	19	48	52	53	59	8948	500	0.193	307	263	13.6
3x120	3.6/6	12.9	21	52	55	57	63	10263	250	0.153	352	298	17.2
3x150	3.6/6	14.3	22	55	58	60	66	11668	250	0.124	397	332	21.5
3x185	3.6/6	15.8	23	59	62	63	70	13604	250	0.0991	453	374	26.5
3x240	3.6/6	18.3	26	64	67	69	76	16315	250	0.0754	529	431	34.3
3x300	3.6/6	20.4	28	69	72	74	81	19233	250	0.0601	599	482	42.9
3x50	6/10	8.2	17	43	46	48	54	6807	500	0.387	205	181	7.2
3x70	6/10	9.8	18	46	49	51	57	7897	500	0.268	253	220	10.0
3x95	6/10	11.4	19	49	53	54	60	9290	500	0.193	307	263	13.6
3x120	6/10	12.9	21	53	56	58	64	10652	250	0.153	352	298	17.2
3x150	6/10	14.3	22	56	59	61	68	12308	250	0.124	397	332	21.5
3x185	6/10	15.8	24	60	63	65	72	14044	250	0.0991	453	374	26.5
3x240	6/10	18.3	26	65	68	70	77	16814	250	0.0754	529	431	34.3
3x300	6/10	20.4	28	70	73	75	83	19702	250	0.0601	599	482	42.9
3x50	8.7/15	8.2	19	48	51	53	59	8007	500	0.387	205	181	7.2
3x70	8.7/15	9.8	20	51	54	56	62	9101	500	0.268	253	220	10.0
3x95	8.7/15	11.4	22	55	58	59	66	10783	250	0.193	307	263	13.6
3x120	8.7/15	12.9	23	58	61	63	70	12196	250	0.153	352	298	17.2
3x150	8.7/15	14.3	24	61	64	66	73	13473	250	0.124	397	332	21.5
3x185	8.7/15	15.8	26	65	68	69	77	15321	250	0.0991	453	374	26.5
3x240	8.7/15	18.3	28	70	73	75	83	18359	250	0.0754	529	431	34.3
3x300	8.7/15	20.4	31	75	78	80	88	21141	250	0.0601	599	482	42.9

Dimension and Electrical Data (cont.)

Cross Section	Tension U ₀ /U	Conductor Diameter	Insulation Diameter	Metallic Sheath Diameter	Sep. Sheath Diameter	Armour Diameter	Outer Sheath Diameter	Cable Weight	Packaging	Max DC Resistance at 20°C	Current Rating in air at 30°C	Current Rating in ground at 20°C	Short Circuit Current for 1s
mm ²	kV	mm	mm	mm	mm	mm	mm	kg/km	m	Ω/km	A	A	kA
3x50	12/20	8.2	21	53	56	57	64	8970	500	0.387	205	181	7.2
3x70	12/20	9.8	22	56	59	60	67	10302	250	0.268	253	220	10.0
3x95	12/20	11.4	24	59	62	64	71	11884	250	0.193	307	263	13.6
3x120	12/20	12.9	25	63	66	67	75	13346	250	0.153	352	298	17.2
3x150	12/20	14.3	26	66	69	70	78	14889	250	0.124	397	332	21.5
3x185	12/20	15.8	28	69	72	74	82	16766	250	0.0991	453	374	26.5
3x240	12/20	18.3	30	75	78	79	88	19703	250	0.0754	529	431	34.3
3x300	12/20	20.4	33	80	83	84	93	22525	200	0.0601	599	482	42.9
3x50	18/30	8.2	26	64	67	69	76	12243	250	0.387	205	181	7.2
3x70	18/30	9.8	27	67	70	72	79	13565	250	0.268	253	220	10.0
3x95	18/30	11.4	28	71	74	75	83	15262	250	0.193	307	263	13.6
3x120	18/30	12.9	30	74	77	79	87	16865	250	0.153	352	298	17.2
3x150	18/30	14.3	31	77	80	82	90	18541	250	0.124	397	332	21.5
3x185	18/30	15.8	33	81	84	85	94	20601	250	0.0991	453	374	26.5
3x240	18/30	18.3	35	86	89	91	100	24032	200	0.0754	529	431	34.3
3x300	18/30	20.4	37	91	94	96	105	27037	200	0.0601	599	482	42.9

Aluminium Cable - Non-armoured XLPE Insulation

3.6/6(7.2) - 18/30(36) kV

1C AL/XLPE/CTS/PVC – NA2XSY



CONSTRUCTION

Conductor	: Stranded Aluminium wire according to IEC 60228 - Class 2 for Circular Stranded Compacted
Conductor Screen	: Extruded Semi Conductive Compound
Insulation	: XLPE Compound
Insulation Screen	: Extruded Semi Conductive Compound
Metallic Screen	: Plain Annealed Copper Tapes
Sheath	: PVC Compound ST 2

APPLICABLE STANDARDS

SNI IEC 60502-2, IEC 60502-2
IEC 60228
IEC 60332-1
IEC 60332-3-22
IEC 60332-3-23
IEC 60332-3-24

Design and Test Guidelines
Conductor
Flame Retardant
Flame Retardant Cat. A
Flame Retardant Cat. B
Flame Retardant Cat. C

Special features on request:
EPR Insulation
Flame Retardant Cat. A, B, C
Flame Retardant Non Category
Anti-termites

Anti-rodent
Oil Resistance
UV Resistance
Low Smoke Zero Halogen

IDENTIFICATIONS

Core Not Applicable



IEC 60332-1
IEC 60332-3-22
IEC 60332-3-23
IEC 60332-3-24



Standard



Excellent



0°C



14 D



Normal Operation Temperature



Short Circuit Temperature

Dimension and Electrical Data

Cross Section	Tension U ₀ /U	Conductor Diameter	Insulation Diameter	Metallic Screen Diameter	Outer Sheath Diameter	Cable Weight	Packaging	Max DC Resistance at 20°C	Current Rating in air at 30°C	Current Rating in ground at 20°C	Short Circuit Current for 1s
mm ²	kV	mm	mm	mm	mm	kg/km	m	Ω/km	A	A	kA
1x50	3.6/6	8.2	16.3	18	21	524	1000	0.6410	184	152	4.7
1x70	3.6/6	9.8	17.4	19	23	595	1000	0.4430	230	186	6.6
1x95	3.6/6	11.4	19.0	20	24	707	1000	0.3200	280	221	9.0
1x120	3.6/6	13.1	20.7	22	26	820	1000	0.2530	324	252	11.3
1x150	3.6/6	14.1	21.7	23	27	909	1000	0.2060	368	281	14.2
1x185	3.6/6	15.9	23.4	25	29	1041	1000	0.1640	424	317	17.5
1x240	3.6/6	18.2	25.8	27	31	1267	1000	0.1250	502	367	22.7
1x300	3.6/6	20.5	28.0	29	34	1513	1000	0.1000	577	414	28.3
1x400	3.6/6	22.9	30.1	32	36	1778	1000	0.0778	673	470	37.8
1x500	3.6/6	26.9	34.2	36	40	2194	1000	0.0605	787	537	47.2
1x630	3.6/6	30.5	37.9	39	44	2740	1000	0.0469	903	610	59.5
1x50	6/10	8.2	16.7	18	22	540	1000	0.6410	184	152	4.7
1x70	6/10	9.8	17.8	19	23	611	1000	0.4430	230	186	6.6
1x95	6/10	11.4	19.4	21	25	724	1000	0.3200	280	221	9.0
1x120	6/10	13.1	21.1	23	26	838	1000	0.2530	324	252	11.3
1x150	6/10	14.1	22.1	24	27	927	1000	0.2060	368	281	14.2
1x185	6/10	15.9	23.8	25	29	1073	1000	0.1640	424	317	17.5
1x240	6/10	18.2	26.2	28	32	1303	1000	0.1250	502	367	22.7
1x300	6/10	20.5	28.4	30	34	1535	1000	0.1000	577	414	28.3
1x400	6/10	22.9	30.9	32	37	1840	1000	0.0778	673	470	37.8
1x500	6/10	26.9	34.6	36	41	2238	1000	0.0605	787	537	47.2
1x630	6/10	30.5	38.3	40	45	2789	1000	0.0469	903	610	59.5
1x50	8.7/15	8.2	18.8	20	24	622	1000	0.6410	184	152	4.7
1x70	8.7/15	9.8	19.9	21	25	697	1000	0.4430	230	186	6.6
1x95	8.7/15	11.4	21.6	23	27	815	1000	0.3200	280	221	9.0
1x120	8.7/15	13.1	23.3	25	29	947	1000	0.2530	324	252	11.3
1x150	8.7/15	14.1	24.3	26	30	1040	1000	0.2060	368	281	14.2
1x185	8.7/15	15.9	26.0	27	32	1194	1000	0.1640	424	317	17.5
1x240	8.7/15	18.2	28.4	30	34	1433	1000	0.1250	502	367	22.7
1x300	8.7/15	20.5	30.6	32	36	1672	1000	0.1000	577	414	28.3
1x400	8.7/15	22.9	33.1	34	39	1971	1000	0.0778	673	470	37.8
1x500	8.7/15	26.9	36.8	38	43	2381	1000	0.0605	787	537	47.2
1x630	8.7/15	30.5	40.4	42	47	2944	1000	0.0469	903	610	59.5

Dimension and Electrical Data (cont.)

Cross Section	Tension U ₀ /U	Conductor Diameter	Insulation Diameter	Metallic Screen Diameter	Outer Sheath Diameter	Cable Weight	Packaging	Max DC Resistance at 20°C	Current Rating in air at 30°C	Current Rating in ground at 20°C	Short Circuit Current for 1s
mm ²	kV	mm	mm	mm	mm	kg/km	m	Ω/km	A	A	kA
1x50	12/20	8.2	20.8	22	26	703	1000	0.6410	184	152	4.7
1x70	12/20	9.8	21.9	23	27	781	1000	0.4430	230	186	6.6
1x95	12/20	11.4	23.5	25	29	917	1000	0.3200	280	221	9.0
1x120	12/20	13.1	25.2	27	31	1041	1000	0.2530	324	252	11.3
1x150	12/20	14.1	26.2	28	32	1151	1000	0.2060	368	281	14.2
1x185	12/20	15.9	28.0	29	34	1296	1000	0.1640	424	317	17.5
1x240	12/20	18.2	30.3	32	36	1543	1000	0.1250	502	367	22.7
1x300	12/20	20.5	32.6	34	39	1806	1000	0.1000	577	414	28.3
1x400	12/20	22.9	35.0	36	41	2114	1000	0.0778	673	470	37.8
1x500	12/20	26.9	38.8	40	45	2537	1000	0.0605	787	537	47.2
1x630	12/20	30.5	42.4	44	49	3113	1000	0.0469	903	610	59.5
1x50	18/30	8.2	25.7	27	31	958	1000	0.6410	184	152	4.7
1x70	18/30	9.8	26.8	28	32	1045	1000	0.4430	230	186	6.6
1x95	18/30	11.4	28.4	30	34	1196	1000	0.3200	280	221	9.0
1x120	18/30	13.1	30.1	32	36	1334	1000	0.2530	324	252	11.3
1x150	18/30	14.1	31.1	33	37	1454	1000	0.2060	368	281	14.2
1x185	18/30	15.9	32.9	34	39	1612	1000	0.1640	424	317	17.5
1x240	18/30	18.2	35.2	37	41	1880	1000	0.1250	502	367	22.7
1x300	18/30	20.5	37.5	39	44	2164	1000	0.1000	577	414	28.3
1x400	18/30	22.9	39.9	41	47	2493	1000	0.0778	673	470	37.8
1x500	18/30	26.9	43.7	45	51	2949	1000	0.0605	787	537	47.2
1x630	18/30	30.5	47.3	49	54	3555	1000	0.0469	903	610	59.5

Aluminium Cable - Non-armoured XLPE Insulation

3.6/6(7.2) - 18/30(36) kV

3C AL/XLPE/CTS/PVC – NA2XSEY



CONSTRUCTION

Conductor	: Stranded Aluminium wire according to IEC 60228 - Class 2 for Circular Stranded Compacted
Conductor Screen	: Extruded Semi Conductive Compound
Insulation	: XLPE Compound
Insulation Screen	: Extruded Semi Conductive Compound
Metallic Screen	: Plain Annealed Copper Tapes
Filler	: PP Yarn Filler
Sheath	: PVC Compound ST 2

APPLICABLE STANDARDS

SNI IEC 60502-2, IEC 60502-2
IEC 60228
IEC 60332-1
IEC 60332-3-22
IEC 60332-3-23
IEC 60332-3-24

Design and Test Guidelines
Conductor
Flame Retardant
Flame Retardant Cat. A
Flame Retardant Cat. B
Flame Retardant Cat. C

Special features on request:
EPR Insulation
Flame Retardant Cat. A, B, C
Flame Retardant Non Category
Anti-termite

Anti-rodent
Oil Resistance
UV Resistance
Low Smoke Zero Halogen

IDENTIFICATIONS

Core Core Brown, Black, Grey

Others colours available upon request



IEC 60332-1
IEC 60332-3-22
IEC 60332-3-23
IEC 60332-3-24



Standard



Excellent



0°C



14 D



Normal
Operation
Temperature



Short
Circuit
Temperature

Dimension and Electrical Data

Cross Section	Tension U ₀ /U	Conductor Diameter	Insulation Diameter	Metallic Screen Diameter	Outer Sheath Diameter	Cable Weight	Packaging	Max DC Resistance at 20°C	Current Rating in air at 20°C	Current Rating in ground at 20°C	Short Circuit Current for 1s
mm ²	kV	mm	mm	mm	mm	kg/km	m	Ω/km	A	A	kA
3x50	3.6/6	8.2	16	18	43	1782	1000	0.6410	158	140	4.7
3x70	3.6/6	9.8	17	19	45	2047	1000	0.4430	196	171	6.6
3x95	3.6/6	11.4	19	20	49	2458	1000	0.3200	236	203	9.0
3x120	3.6/6	13.1	21	22	53	2883	1000	0.2530	273	232	11.3
3x150	3.6/6	14.1	22	23	55	3213	500	0.2060	309	260	14.2
3x185	3.6/6	15.9	23	25	59	3710	500	0.1640	355	294	17.5
3x240	3.6/6	18.2	26	27	65	4518	500	0.1250	415	340	22.7
3x300	3.6/6	20.5	28	29	70	5387	500	0.1000	475	384	28.3
3x50	6/10	8.2	17	18	44	1858	1000	0.6410	158	140	4.7
3x70	6/10	9.8	18	19	47	2128	1000	0.4430	196	171	6.6
3x95	6/10	11.4	19	21	50	2568	1000	0.3200	236	203	9.0
3x120	6/10	13.1	21	23	54	3001	1000	0.2530	273	232	11.3
3x150	6/10	14.1	22	24	57	3336	500	0.2060	309	260	14.2
3x185	6/10	15.9	24	25	61	3841	500	0.1640	355	294	17.5
3x240	6/10	18.2	26	28	66	4661	500	0.1250	415	340	22.7
3x300	6/10	20.5	28	30	71	5507	500	0.1000	475	384	28.3
3x50	8.7/15	8.2	19	20	49	2219	1000	0.6410	158	140	4.7
3x70	8.7/15	9.8	20	21	52	2508	1000	0.4430	196	171	6.6
3x95	8.7/15	11.4	22	23	55	2950	1000	0.3200	236	203	9.0
3x120	8.7/15	13.1	23	25	59	3409	1000	0.2530	273	232	11.3
3x150	8.7/15	14.1	24	26	62	3761	500	0.2060	309	260	14.2
3x185	8.7/15	15.9	26	27	66	4322	500	0.1640	355	294	17.5
3x240	8.7/15	18.2	28	30	71	5148	500	0.1250	415	340	22.7
3x300	8.7/15	20.5	31	32	76	6062	500	0.1000	475	384	28.3

Dimension and Electrical Data (cont.)

Cross Section	Tension U ₀ /U	Conductor Diameter	Insulation Diameter	Metallic Screen Diameter	Outer Sheath Diameter	Cable Weight	Packaging	Max DC Resistance at 20°C	Current Rating in air at 20°C	Current Rating in ground at 20°C	Short Circuit Current for 1s
mm ²	kV	mm	mm	mm	mm	kg/km	m	Ω/km	A	A	kA
3x50	12/20	8.2	21	22	54	2582	1000	0.6410	158	140	4.7
3x70	12/20	9.8	22	23	56	2888	1000	0.4430	196	171	6.6
3x95	12/20	11.4	24	25	60	3355	1000	0.3200	236	203	9.0
3x120	12/20	13.1	25	27	64	3839	1000	0.2530	273	232	11.3
3x150	12/20	14.1	26	28	66	4206	500	0.2060	309	260	14.2
3x185	12/20	15.9	28	29	70	4762	500	0.1640	355	294	17.5
3x240	12/20	18.2	30	32	76	5656	500	0.1250	415	340	22.7
3x300	12/20	20.5	33	34	81	6567	500	0.1000	475	384	28.3
3x50	18/30	8.2	26	27	65	3567	1000	0.6410	158	140	4.7
3x70	18/30	9.8	27	28	67	3913	1000	0.4430	196	171	6.6
3x95	18/30	11.4	28	30	71	4471	500	0.3200	236	203	9.0
3x120	18/30	13.1	30	32	75	5016	500	0.2530	273	232	11.3
3x150	18/30	14.1	31	33	78	5422	500	0.2060	309	260	14.2
3x185	18/30	15.9	33	34	81	6040	500	0.1640	355	294	17.5
3x240	18/30	18.2	35	37	87	7022	500	0.1250	415	340	22.7
3x300	18/30	20.5	38	39	92	8012	500	0.1000	475	384	28.3

Aluminium Cable - Armoured XLPE Insulation

3.6/6(7.2) - 18/30(36) kV

1C AL/XLPE/CTS/PVC/DATA/PVC – NA2XSYB(AL)Y



CONSTRUCTION

Conductor	: Stranded Aluminium wire according to IEC 60228 - Class 2 for Circular Stranded Compacted
Conductor Screen	: Extruded Semi Conductive Compound
Insulation	: XLPE Compound
Insulation Screen	: Extruded Semi Conductive Compound
Metallic Screen	: Plain Annealed Copper Tapes
Separation Sheath	: PVC Compound ST 2
Metallic Armour	: Double Aluminium Tapes
Sheath	: PVC Compound ST 2

APPLICABLE STANDARDS

SNI IEC 60502-2, IEC 60502-2
IEC 60228
IEC 60332-1
IEC 60332-3-22
IEC 60332-3-23
IEC 60332-3-24

Design and Test Guidelines
Conductor
Flame Retardant
Flame Retardant Cat. A
Flame Retardant Cat. B
Flame Retardant Cat. C

Special features on request:
EPR Insulation
Flame Retardant Cat. A, B, C
Flame Retardant Non Category
Anti-termites

Anti-rodent
Oil Resistance
UV Resistance
Low Smoke Zero Halogen

IDENTIFICATIONS

Core Not Applicable



IEC 60332-1
IEC 60332-3-22
IEC 60332-3-23
IEC 60332-3-24



Standard



Excellent



0°C



14 D



Normal
Operation
Temperature



Short
Circuit
Temperature

Dimension and Electrical Data

Cross Section	Tension U ₀ /U	Conductor Diameter	Insulation Diameter	Sep. Sheath Diameter	Armour Diameter	Outer Sheath Diameter	Cable Weight	Packaging	Max DC Resistance at 20°C	Current Rating in air at 30°C	Current Rating in ground at 20°C	Short Circuit Current for 1s
mm ²	kV	mm	mm	mm	mm	mm	kg/km	m	Ω/km	A	A	kA
1x50	3.6/6	8.2	16.3	21	24	27	824	1000	0.6410	184	152	4.7
1x70	3.6/6	9.8	17.4	22	25	28	908	1000	0.4430	230	186	6.6
1x95	3.6/6	11.4	19.0	24	27	30	1040	1000	0.3200	280	221	9.0
1x120	3.6/6	13.1	20.7	26	28	32	1189	1000	0.2530	324	252	11.3
1x150	3.6/6	14.1	21.7	27	29	33	1290	1000	0.2060	368	281	14.2
1x185	3.6/6	15.9	23.4	28	31	35	1460	1000	0.1640	424	317	17.5
1x240	3.6/6	18.2	25.8	31	33	37	1721	1000	0.1250	502	367	22.7
1x300	3.6/6	20.5	28.0	33	36	40	1999	1000	0.1000	577	414	28.3
1x400	3.6/6	22.9	30.1	35	38	42	2294	1000	0.0778	673	470	37.8
1x500	3.6/6	26.9	34.2	39	42	46	2768	1000	0.0605	787	537	47.2
1x630	3.6/6	30.5	37.9	43	45	50	3365	1000	0.0469	903	610	59.5
1x50	6/10	8.2	16.7	22	24	27	844	1000	0.6410	184	152	4.7
1x70	6/10	9.8	17.8	23	25	29	929	1000	0.4430	230	186	6.6
1x95	6/10	11.4	19.4	24	27	30	1076	1000	0.3200	280	221	9.0
1x120	6/10	13.1	21.1	26	29	32	1227	1000	0.2530	324	252	11.3
1x150	6/10	14.1	22.1	27	30	33	1329	1000	0.2060	368	281	14.2
1x185	6/10	15.9	23.8	29	31	35	1501	1000	0.1640	424	317	17.5
1x240	6/10	18.2	26.2	31	34	38	1747	1000	0.1250	502	367	22.7
1x300	6/10	20.5	28.4	33	36	40	2026	1000	0.1000	577	414	28.3
1x400	6/10	22.9	30.9	36	38	43	2350	1000	0.0778	673	470	37.8
1x500	6/10	26.9	34.6	40	42	47	2799	1000	0.0605	787	537	47.2
1x630	6/10	30.5	38.3	43	46	50	3399	1000	0.0469	903	610	59.5
1x50	8.7/15	8.2	18.8	24	26	30	967	1000	0.6410	184	152	4.7
1x70	8.7/15	9.8	19.9	25	27	31	1056	1000	0.4430	230	186	6.6
1x95	8.7/15	11.4	21.6	27	29	33	1210	1000	0.3200	280	221	9.0
1x120	8.7/15	13.1	23.3	28	31	34	1352	1000	0.2530	324	252	11.3
1x150	8.7/15	14.1	24.3	29	32	36	1474	1000	0.2060	368	281	14.2
1x185	8.7/15	15.9	26.0	31	34	37	1636	1000	0.1640	424	317	17.5
1x240	8.7/15	18.2	28.4	33	36	40	1908	1000	0.1250	502	367	22.7
1x300	8.7/15	20.5	30.6	36	38	42	2196	1000	0.1000	577	414	28.3
1x400	8.7/15	22.9	33.1	38	41	45	2529	1000	0.0778	673	470	37.8
1x500	8.7/15	26.9	36.8	42	44	49	2992	1000	0.0605	787	537	47.2
1x630	8.7/15	30.5	40.4	45	48	53	3606	1000	0.0469	903	610	59.5

Dimension and Electrical Data (cont.)

Cross Section	Tension U ₀ /U	Conductor Diameter	Insulation Diameter	Sep. Sheath Diameter	Armour Diameter	Outer Sheath Diameter	Cable Weight	Packaging	Max DC Resistance at 20°C	Current Rating in air at 30°C	Current Rating in ground at 20°C	Short Circuit Current for 1s
mm ²	kV	mm	mm	mm	mm	mm	kg/km	m	Ω/km	A	A	kA
1x50	12/20	8.2	20.8	26	28	32	1073	1000	0.6410	184	152	4.7
1x70	12/20	9.8	21.9	27	29	33	1180	1000	0.4430	230	186	6.6
1x95	12/20	11.4	23.5	29	31	35	1324	1000	0.3200	280	221	9.0
1x120	12/20	13.1	25.2	30	33	37	1488	1000	0.2530	324	252	11.3
1x150	12/20	14.1	26.2	31	34	38	1597	1000	0.2060	368	281	14.2
1x185	12/20	15.9	28.0	33	36	40	1781	1000	0.1640	424	317	17.5
1x240	12/20	18.2	30.3	35	38	42	2062	1000	0.1250	502	367	22.7
1x300	12/20	20.5	32.6	38	40	45	2358	1000	0.1000	577	414	28.3
1x400	12/20	22.9	35.0	40	43	47	2701	1000	0.0778	673	470	37.8
1x500	12/20	26.9	38.8	44	46	51	3177	1000	0.0605	787	537	47.2
1x630	12/20	30.5	42.4	47	50	55	3804	1000	0.0469	903	610	59.5
1x50	18/30	8.2	25.7	31	33	37	1396	1000	0.6410	184	152	4.7
1x70	18/30	9.8	26.8	32	34	38	1515	1000	0.4430	230	186	6.6
1x95	18/30	11.4	28.4	33	36	40	1672	1000	0.3200	280	221	9.0
1x120	18/30	13.1	30.1	35	38	42	1851	1000	0.2530	324	252	11.3
1x150	18/30	14.1	31.1	36	39	43	1968	1000	0.2060	368	281	14.2
1x185	18/30	15.9	32.9	38	40	45	2169	1000	0.1640	424	317	17.5
1x240	18/30	18.2	35.2	40	43	47	2471	1000	0.1250	502	367	22.7
1x300	18/30	20.5	37.5	42	45	50	2764	1000	0.1000	577	414	28.3
1x400	18/30	22.9	39.9	45	47	53	3151	1000	0.0778	673	470	37.8
1x500	18/30	26.9	43.7	49	51	56	3659	1000	0.0605	787	537	47.2
1x630	18/30	30.5	47.3	52	55	60	4317	1000	0.0469	903	610	59.5

Aluminium Cable - Armoured XLPE Insulation

3.6/6(7.2) - 18/30(36) kV

3C AL/XLPE/CTS/PVC/DSTA/PVC – NA2XSEYBY

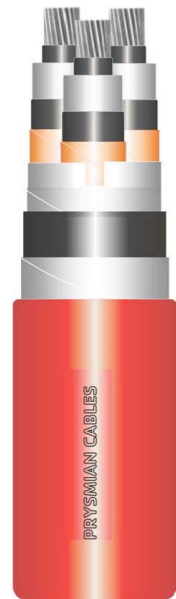

CONSTRUCTION

Conductor	: Stranded Aluminium wire according to IEC 60228 - Class 2 for Circular Stranded Compacted
Conductor Screen	: Extruded Semi Conductive Compound
Insulation	: XLPE Compound
Insulation Screen	: Extruded Semi Conductive Compound
Metallic Screen	: Plain Annealed Copper Tapes
Filler	: PP Yarn Filler
Separation Sheath	: PVC ST2 Compound
Metallic Armour	: Double Galvanized Steel Tapes
Sheath	: PVC ST2 Compound

APPLICABLE STANDARDS

SNI IEC 60502-2, IEC 60502-2
IEC 60228
IEC 60332-1
IEC 60332-3-22
IEC 60332-3-23
IEC 60332-3-24

Special features on request:
EPR Insulation
Flame Retardant Cat. A, B, C
Flame Retardant Non Category
Anti-termites

Design and Test Guidelines
Conductor
Flame Retardant
Flame Retardant Cat. A
Flame Retardant Cat. B
Flame Retardant Cat. C

Anti-rodent
Oil Resistance
UV Resistance
Low Smoke Zero Halogen

IDENTIFICATIONS

Core: Brown, Black, Grey

Others: colours available upon request



IEC 60332-1
IEC 60332-3-22
IEC 60332-3-23
IEC 60332-3-24



Standard



Excellent



0°C



14 D



Normal Operation Temperature



Short Circuit Temperature

Dimension and Electrical Data

Cross Section	Tension U ₀ /U	Conductor Diameter	Insulation Diameter	Sep. Sheath Diameter	Armour Diameter	Outer Sheath Diameter	Cable Weight	Packaging	Max DC Resistance at 20°C	Current Rating in air at 30°C	Current Rating in ground at 20°C	Short Circuit Current for 1s
mm ²	kV	mm	mm	mm	mm	mm	kg/km	m	Ω/km	A	A	kA
3x50	3.6/6	8.2	16.3	42	44	49	2845	1000	0.387	205	181	7.2
3x70	3.6/6	9.8	17.4	44	47	51	3172	1000	0.268	253	220	10.0
3x95	3.6/6	11.3	19.0	48	50	55	3669	1000	0.193	307	263	13.6
3x120	3.6/6	12.8	20.7	51	54	59	4211	1000	0.153	352	298	17.2
3x150	3.6/6	14.2	21.7	54	56	62	4598	1000	0.124	397	332	21.5
3x185	3.6/6	15.7	23.4	57	60	65	5188	500	0.0991	453	374	26.5
3x240	3.6/6	18.1	25.8	62	65	71	6127	500	0.0754	529	431	34.3
3x300	3.6/6	20.2	28.0	67	70	76	7118	500	0.0601	599	482	42.9
3x50	6/10	8.2	16.7	43	45	so	2970	1000	0.387	205	181	7.2
3x70	6/10	9.8	17.8	45	48	53	3302	1000	0.268	253	220	10.0
3x95	6/10	11.3	19.4	49	51	56	3807	1000	0.193	307	263	13.6
3x120	6/10	12.8	21.1	52	55	60	4330	1000	0.153	352	298	17.2
3x150	6/10	14.2	22.1	54	57	63	4721	1000	0.124	397	332	21.5
3x185	6/10	15.7	23.8	58	61	67	5317	500	0.0991	453	374	26.5
3x240	6/10	18.1	26.2	63	66	72	6265	500	0.0754	529	431	34.3
3x300	6/10	20.2	28.4	68	71	77	7263	500	0.0601	599	482	42.9
3x50	8.7/15	8.2	18.8	47	50	55	3425	1000	0.387	205	181	7.2
3x70	8.7/15	9.8	19.9	50	52	58	3774	1000	0.268	253	220	10.0
3x95	8.7/15	11.3	21.6	53	56	61	4332	1000	0.193	307	263	13.6
3x120	8.7/15	12.8	23.3	57	59	65	4883	1000	0.153	352	298	17.2
3x150	8.7/15	14.2	24.3	59	62	68	5291	500	0.124	397	332	21.5
3x185	8.7/15	15.7	26.0	63	65	72	5914	500	0.0991	453	374	26.5
3x240	8.7/15	18.1	28.4	68	70	77	6902	500	0.0754	529	431	34.3
3x300	8.7/15	20.2	30.6	73	77	84	8687	500	0.0601	599	482	42.9

Dimension and Electrical Data (cont.)

Cross Section	Tension U ₀ /U	Conductor Diameter	Insulation Diameter	Sep. Sheath Diameter	Metallic Screen Diameter	Outer Sheath Diameter	Cable Weight	Packaging	Max DC Resistance at 20°C	Current Rating in air at 30°C	Current Rating in ground at 20°C	Short Circuit Current for 1s
mm ²	kV	mm	mm	mm	mm	mm	kg/km	m	Ω/km	A	A	kA
3x50	12/20	8.2	20.8	52	54	60	3895	1000	0.387	205	181	7.2
3x70	12/20	9.8	21.9	54	57	62	4261	1000	0.268	253	220	10.0
3x95	12/20	11.3	23.5	58	60	66	4816	1000	0.193	307	263	13.6
3x120	12/20	12.8	25.2	61	64	70	5389	500	0.153	352	298	17.2
3x150	12/20	14.2	26.2	63	66	72	5812	500	0.124	397	332	21.5
3x185	12/20	15.7	28.0	67	70	76	6494	500	0.0991	453	374	26.5
3x240	12/20	18.1	30.3	72	76	83	8262	500	0.0754	529	431	34.3
3x300	12/20	20.2	32.6	77	81	88	9339	500	0.0601	599	482	42.9
3x50	18/30	8.2	25.7	62	65	71	5174	500	0.387	205	181	7.2
3x70	18/30	9.8	26.8	65	67	74	5582	500	0.268	253	220	10.0
3x95	18/30	11.3	28.4	68	71	77	6196	500	0.193	307	263	13.6
3x120	18/30	12.8	30.1	72	76	83	7608	500	0.153	352	298	17.2
3x150	18/30	14.2	31.1	74	78	85	8092	500	0.124	397	332	21.5
3x185	18/30	15.7	32.9	78	82	89	8839	500	0.0991	453	374	26.5
3x240	18/30	18.1	35.2	83	87	95	10003	250	0.0754	529	431	34.3
3x300	18/30	20.2	37.5	88	92	100	11159	250	0.0601	599	482	42.9

Aluminium Cable - Armoured XLPE Insulation

3.6/6(7.2) - 18/30(36) kV

1C AL/XLPE/CTS/PVC/AWA/PVC – NA2XSyr(AL)Y



CONSTRUCTION

Conductor	: Stranded Aluminium wire according to IEC 60228 - Class 2 for Circular Stranded Compacted
Conductor Screen	: Extruded Semi Conductive Compound
Insulation	: XLPE Compound
Insulation Screen	: Extruded Semi Conductive Compound
Metallic Screen	: Plain Annealed Copper Tapes
Separation Sheath	: PVC Compound ST 2
Metallic Armour	: Aluminium Wires Armour
Sheath	: PVC Compound ST 2

APPLICABLE STANDARDS

SNI IEC 60502-2, IEC 60502-2
IEC 60228
IEC 60332-1
IEC 60332-3-22
IEC 60332-3-23
IEC 60332-3-24

Design and Test Guidelines
Conductor
Flame Retardant
Flame Retardant Cat. A
Flame Retardant Cat. B
Flame Retardant Cat. C

Special features on request:
EPR Insulation
Flame Retardant Cat. A, B, C
Flame Retardant Non Category
Anti-termite

Anti-rodent
Oil Resistance
UV Resistance
Low Smoke Zero Halogen

IDENTIFICATIONS

Core Not Applicable

Others colours available upon request



IEC 60332-1
IEC 60332-3-22
IEC 60332-3-23
IEC 60332-3-24



Standard



Excellent



0°C



14 D



Normal Operation Temperature



Short Circuit Temperature

Dimension and Electrical Data

Cross Section	Tension U ₀ /U	Conductor Diameter	Insulation Diameter	Sep. Sheath Diameter	Armour Diameter	Outer Sheath Diameter	Cable Weight	Packaging	Max DC Resistance at 20°C	Current Rating in air at 20°C	Current Rating in ground at 20°C	Short Circuit Current for 1s
mm ²	kV	mm	mm	mm	mm	mm	kg/km	m	Ω/km	A	A	kA
1x50	3.6/6	8.2	16.3	21	25	29	968	1000	0.6410	184	152	4.7
1x70	3.6/6	9.8	17.4	22	26	30	1060	1000	0.4430	230	186	6.6
1x95	3.6/6	11.4	19.0	24	27	32	1217	1000	0.3200	280	221	9.0
1x120	3.6/6	13.1	20.7	26	29	34	1355	1000	0.2530	324	252	11.3
1x150	3.6/6	14.1	21.7	27	30	35	1481	1000	0.2060	368	281	14.2
1x185	3.6/6	15.9	23.4	28	33	37	1744	1000	0.1640	424	317	17.5
1x240	3.6/6	18.2	25.8	31	35	40	2015	1000	0.1250	502	367	22.7
1x300	3.6/6	20.5	28.0	33	37	42	2312	1000	0.1000	577	414	28.3
1x400	3.6/6	22.9	30.1	35	39	45	2649	1000	0.0778	673	470	37.8
1x500	3.6/6	26.9	34.2	39	44	so	3291	1000	0.0605	787	537	47.2
1x630	3.6/6	30.5	37.9	43	48	54	3932	1000	0.0469	903	610	59.5
1x50	6/10	8.2	16.7	22	25	29	994	1000	0.6410	184	152	4.7
1x70	6/10	9.8	17.8	23	26	31	1095	1000	0.4430	230	186	6.6
1x95	6/10	11.4	19.4	24	28	32	1239	1000	0.3200	280	221	9.0
1x120	6/10	13.1	21.1	26	30	35	1478	1000	0.2530	324	252	11.3
1x150	6/10	14.1	22.1	27	31	36	1612	1000	0.2060	368	281	14.2
1x185	6/10	15.9	23.8	29	33	38	1779	1000	0.1640	424	317	17.5
1x240	6/10	18.2	26.2	31	35	40	2060	1000	0.1250	502	367	22.7
1x300	6/10	20.5	28.4	33	38	43	2359	1000	0.1000	577	414	28.3
1x400	6/10	22.9	30.9	36	41	47	2844	1000	0.0778	673	470	37.8
1x500	6/10	26.9	34.6	40	45	50	3335	1000	0.0605	787	537	47.2
1x630	6/10	30.5	38.3	43	48	54	3978	1000	0.0469	903	610	59.5
1x50	8.7/15	8.2	18.8	24	27	32	1127	1000	0.6410	184	152	4.7
1x70	8.7/15	9.8	19.9	25	28	33	1238	1000	0.4430	230	186	6.6
1x95	8.7/15	11.4	21.6	27	31	35	1469	1000	0.3200	280	221	9.0
1x120	8.7/15	13.1	23.3	28	32	37	1638	1000	0.2530	324	252	11.3
1x150	8.7/15	14.1	24.3	29	33	38	1759	1000	0.2060	368	281	14.2
1x185	8.7/15	15.9	26.0	31	35	40	1949	1000	0.1640	424	317	17.5
1x240	8.7/15	18.2	28.4	33	37	43	2240	1000	0.1250	502	367	22.7
1x300	8.7/15	20.5	30.6	36	40	45	2527	1000	0.1000	577	414	28.3
1x400	8.7/15	22.9	33.1	38	43	49	3044	1000	0.0778	673	470	37.8
1x500	8.7/15	26.9	36.8	42	47	53	3550	1000	0.0605	787	537	47.2
1x630	8.7/15	30.5	40.4	45	51	57	4207	1000	0.0469	903	610	59.5

Dimension and Electrical Data (cont.)

Cross Section	Tension U ₀ /U	Conductor Diameter	Insulation Diameter	Sep. Sheath Diameter	Armour Diameter	Outer Sheath Diameter	Cable Weight	Packaging	Max DC Resistance at 20°C	Current Rating in air at 20°C	Current Rating in ground at 20°C	Short Circuit Current for 1s
mm ²	kV	mm	mm	mm	mm	mm	kg/km	m	Ω/km	A	A	kA
1x50	3.6/6	8.2	20.8	26	29	34	1263	1000	0.6410	184	152	4.7
1x70	3.6/6	9.8	21.9	27	31	36	1455	1000	0.4430	230	186	6.6
1x95	3.6/6	11.4	23.5	29	33	38	1619	1000	0.3200	280	221	9.0
1x120	3.6/6	13.1	25.2	30	34	39	1795	1000	0.2530	324	252	11.3
1x150	3.6/6	14.1	26.2	31	35	40	1910	1000	0.2060	368	281	14.2
1x185	3.6/6	15.9	28.0	33	37	42	2116	1000	0.1640	424	317	17.5
1x240	3.6/6	18.2	30.3	35	39	45	2395	1000	0.1250	502	367	22.7
1x300	3.6/6	20.5	32.6	38	43	48	2874	1000	0.1000	577	414	28.3
1x400	3.6/6	22.9	35.0	40	45	51	3239	1000	0.0778	673	470	37.8
1x500	3.6/6	26.9	38.8	44	49	55	3757	1000	0.0605	787	537	47.2
1x630	3.6/6	30.5	42.4	47	52	59	4427	1000	0.0469	903	610	59.5
1x50	6/10	8.2	25.7	31	35	40	1702	1000	0.6410	184	152	4.7
1x70	6/10	9.8	26.8	32	36	41	1817	1000	0.4430	230	186	6.6
1x95	6/10	11.4	28.4	33	38	43	2005	1000	0.3200	280	221	9.0
1x120	6/10	13.1	30.1	35	39	45	2185	1000	0.2530	324	252	11.3
1x150	6/10	14.1	31.1	36	41	47	2461	1000	0.2060	368	281	14.2
1x185	6/10	15.9	32.9	38	43	49	2684	1000	0.1640	424	317	17.5
1x240	6/10	18.2	35.2	40	45	51	3021	1000	0.1250	502	367	22.7
1x300	6/10	20.5	37.5	42	48	54	3334	1000	0.1000	577	414	28.3
1x400	6/10	22.9	39.9	45	50	56	3759	1000	0.0778	673	470	37.8
1x500	6/10	26.9	43.7	49	54	60	4309	500	0.0605	787	537	47.2
1x630	6/10	30.5	47.3	52	57	64	5010	500	0.0469	903	610	59.5

Aluminium Cable - Armoured XLPE Insulation

3.6/6(7.2) - 18/30(36) kV

3C AL/XLPE/CTS/PVC/SWA/PVC – NA2XSEYRY

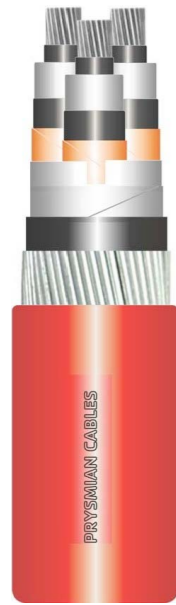

CONSTRUCTION

Conductor	: Stranded Aluminium wire according to IEC 60228 - Class 2 for Circular Stranded Compacted
Conductor Screen	: Extruded Semi Conductive Compound
Insulation	: XLPE Compound
Insulation Screen	: Extruded Semi Conductive Compound
Metallic Screen	: Plain Annealed Copper Tapes
Filler	: PP Yarn Filler
Separation Sheath	: PVC ST2 Compound
Metallic Armour	: Galvanized Steel Wires Armour
Sheath	: PVC ST2 Compound

APPLICABLE STANDARDS

SNI IEC 60502-2, IEC 60502-2
IEC 60228
IEC 60332-1
IEC 60332-3-22
IEC 60332-3-23
IEC 60332-3-24

Special features on request:
EPR Insulation
Flame Retardant Cat. A, B, C
Flame Retardant Non Category
Anti-termites

Design and Test Guidelines
Conductor
Flame Retardant
Flame Retardant Cat. A
Flame Retardant Cat. B
Flame Retardant Cat. C

Anti-rodent
Oil Resistance
UV Resistance
Low Smoke Zero Halogen

IDENTIFICATIONS

Core Brown, Black, Grey

Others colours available upon request



IEC 60332-1
IEC 60332-3-22
IEC 60332-3-23
IEC 60332-3-24



Standard



Excellent



0°C



14 D



Normal
Operation
Temperature



Short
Circuit
Temperature

Dimension and Electrical Data

Cross Section	Tension U ₀ /U	Conductor Diameter	Insulation Diameter	Sep. Sheath Diameter	Armour Diameter	Outer Sheath Diameter	Cable Weight	Packaging	Max DC Resistance at 20°C	Current Rating in air at 30°C	Current Rating in ground at 20°C	Short Circuit Current for 1s
mm ²	kV	mm	mm	mm	mm	mm	kg/km	m	Ω/km	A	A	kA
3x50	3.6/6	8.2	16	42	47	52	4290	1000	0.6410	159	140	4.7
3x70	3.6/6	9.8	17	45	50	54	4672	1000	0.4430	196	171	6.6
3x95	3.6/6	11.4	19	48	53	58	5323	500	0.3200	238	204	9.0
3x120	3.6/6	13.1	21	52	57	62	5960	500	0.2530	274	232	11.3
3x150	3.6/6	14.1	22	54	59	65	6407	500	0.2060	309	259	14.2
3x185	3.6/6	15.9	23	58	63	69	7118	500	0.1640	354	293	17.5
3x240	3.6/6	18.2	26	63	69	75	9048	500	0.1250	415	338	22.7
3x300	3.6/6	20.5	28	68	74	81	10254	250	0.1000	472	380	28.3
3x50	6/10	8.2	17	43	48	53	4459	1000	0.6410	159	140	4.7
3x70	6/10	9.8	18	45	50	56	4847	1000	0.4430	196	171	6.6
3x95	6/10	11.4	19	49	54	59	5474	500	0.3200	238	204	9.0
3x120	6/10	13.1	21	53	58	63	6117	500	0.2530	274	232	11.3
3x150	6/10	14.1	22	55	60	66	6569	500	0.2060	309	259	14.2
3x185	6/10	15.9	24	59	64	70	7286	500	0.1640	354	293	17.5
3x240	6/10	18.2	26	64	70	77	9293	500	0.1250	415	338	22.7
3x300	6/10	20.5	28	68	75	82	10463	250	0.1000	472	380	28.3
3x50	8.7/15	8.2	19	48	53	58	5061	500	0.6410	159	140	4.7
3x70	8.7/15	9.8	20	50	55	61	5467	500	0.4430	196	171	6.6
3x95	8.7/15	11.4	22	54	59	65	6155	500	0.3200	238	204	9.0
3x120	8.7/15	13.1	23	57	62	68	6827	500	0.2530	274	232	11.3
3x150	8.7/15	14.1	24	59	66	72	8065	500	0.2060	309	259	14.2
3x185	8.7/15	15.9	26	63	70	76	8885	500	0.1640	354	293	17.5
3x240	8.7/15	18.2	28	68	75	82	10103	250	0.1250	415	338	22.7
3x300	8.7/15	20.5	31	73	79	87	11356	250	0.1000	472	380	28.3

Dimension and Electrical Data (cont.)

Cross Section	Tension U ₀ /U	Conductor Diameter	Insulation Diameter	Sep. Sheath Diameter	Metallic Screen Diameter	Outer Sheath Diameter	Cable Weight	Packaging	Max DC Resistance at 20°C	Current Rating in air at 30°C	Current Rating in ground at 20°C	Short Circuit Current for 1s
mm ²	kV	mm	mm	mm	mm	mm	kg/km	m	Ω/km	A	A	kA
3x50	12/20	8.2	21	52	57	63	5651	500	0.6410	159	140	4.7
3x70	12/20	9.8	22	54	59	65	6115	500	0.4430	196	171	6.6
3x95	12/20	11.4	24	58	63	69	6793	500	0.3200	238	204	9.0
3x120	12/20	13.1	25	62	68	74	8306	500	0.2530	274	232	11.3
3x150	12/20	14.1	26	64	70	77	8840	500	0.2060	309	259	14.2
3x185	12/20	15.9	28	67	74	81	9644	500	0.1640	354	293	17.5
3x240	12/20	18.2	30	72	79	86	10880	250	0.1250	415	338	22.7
3x300	12/20	20.5	33	77	84	91	12118	250	0.1000	472	380	28.3
3x50	18/30	8.2	26	63	69	75	8111	500	0.6410	159	140	4.7
3x70	18/30	9.8	27	65	71	78	8626	500	0.4430	196	171	6.6
3x95	18/30	11.4	28	68	75	82	9442	500	0.3200	238	204	9.0
3x120	18/30	13.1	30	72	78	86	10235	250	0.2530	274	232	11.3
3x150	18/30	14.1	31	74	81	88	10810	250	0.2060	309	259	14.2
3x185	18/30	15.9	33	78	84	92	11677	250	0.1640	354	293	17.5
3x240	18/30	18.2	35	83	89	98	13007	250	0.1250	415	338	22.7
3x300	18/30	20.5	38	88	94	103	14447	250	0.1000	472	380	28.3

Aluminium Cable - Armoured XLPE Insulation

3.6/6(7.2) - 18/30(36) kV

3C AL/XLPE/CTS/PVC/SFA/PVC – NA2XSEYFY



CONSTRUCTION

Conductor	: Stranded Aluminium wire according to IEC 60228 - Class 2 for Circular Stranded Compacted
Conductor Screen	: Extruded Semi Conductive Compound
Insulation	: XLPE Compound
Insulation Screen	: Extruded Semi Conductive Compound
Metallic Screen	: Plain Annealed Copper Tapes
Filler	: PP Yarn Filler
Separation Sheath	: PVC ST2 Compound
Metallic Armour	: Galvanized Steel Flat Armour
Sheath	: PVC ST2 Compound

APPLICABLE STANDARDS

SNI IEC 60502-2, IEC 60502-2
IEC 60228
IEC 60332-1
IEC 60332-3-22
IEC 60332-3-23
IEC 60332-3-24

Design and Test Guidelines
Conductor
Flame Retardant
Flame Retardant Cat. A
Flame Retardant Cat. B
Flame Retardant Cat. C

Special features on request:
EPR Insulation
Flame Retardant Cat. A, B, C
Flame Retardant Non Category
Anti-termite

Anti-rodent
Oil Resistance
UV Resistance
Low Smoke Zero Halogen

IDENTIFICATIONS

Core Brown, Black, Grey

Others colours available upon request



IEC 60332-1
IEC 60332-3-22
IEC 60332-3-23
IEC 60332-3-24



Standard



Excellent



0°C



14 D



Normal Operation Temperature



Short Circuit Temperature

Dimension and Electrical Data

Cross Section	Tension U ₀ /U	Conductor Diameter	Insulation Diameter	Sep. Sheath Diameter	Armour Diameter	Outer Sheath Diameter	Cable Weight	Packaging	Max DC Resistance at 20°C	Current Rating in air at 30°C	Current Rating in ground at 20°C	Short Circuit Current for 1s
mm ²	kV	mm	mm	mm	mm	mm	kg/km	m	Ω/km	A	A	kA
3x50	3.6/6	8.2	16.3	42	43	48	2915	1000	0.6410	159	140	4.7
3x70	3.6/6	9.8	17.4	44	46	51	3277	1000	0.4430	196	171	6.6
3x95	3.6/6	11.4	19.0	48	49	55	3796	1000	0.3200	238	204	9.0
3x120	3.6/6	13.1	20.7	51	53	59	4304	1000	0.2530	274	232	11.3
3x150	3.6/6	14.1	21.7	53	55	61	4707	1000	0.2060	309	259	14.2
3x185	3.6/6	15.9	23.4	57	59	65	5313	500	0.1640	354	293	17.5
3x240	3.6/6	18.2	25.8	62	64	70	6246	500	0.1250	415	338	22.7
3x300	3.6/6	20.5	28.0	67	69	76	7261	500	0.1000	472	380	28.3
3x50	6/10	8.2	16.7	43	44	so	3051	1000	0.6410	159	140	4.7
3x70	6/10	9.8	17.8	45	47	52	3394	1000	0.4430	196	171	6.6
3x95	6/10	11.4	19.4	48	50	56	3893	1000	0.3200	238	204	9.0
3x120	6/10	13.1	21.1	52	54	60	4434	1000	0.2530	274	232	11.3
3x150	6/10	14.1	22.1	54	56	62	4814	1000	0.2060	309	259	14.2
3x185	6/10	15.9	23.8	58	60	66	5457	500	0.1640	354	293	17.5
3x240	6/10	18.2	26.2	63	65	72	6394	500	0.1250	415	338	22.7
3x300	6/10	20.5	28.4	68	69	77	7392	500	0.1000	472	380	28.3
3x50	8.7/15	8.2	18.8	47	49	55	3532	1000	0.6410	159	140	4.7
3x70	8.7/15	9.8	19.9	so	51	57	3894	1000	0.4430	196	171	6.6
3x95	8.7/15	11.4	21.6	53	55	61	4445	1000	0.3200	238	204	9.0
3x120	8.7/15	13.1	23.3	57	58	65	4987	1000	0.2530	274	232	11.3
3x150	8.7/15	14.1	24.3	59	61	67	5411	500	0.2060	309	259	14.2
3x185	8.7/15	15.9	26.0	63	64	71	6051	500	0.1640	354	293	17.5
3x240	8.7/15	18.2	28.4	68	69	77	7032	500	0.1250	415	338	22.7
3x300	8.7/15	20.5	30.6	73	74	82	8093	500	0.1000	472	380	28.3

Dimension and Electrical Data (cont.)

Cross Section	Tension U ₀ /U	Conductor Diameter	Insulation Diameter	Sep. Sheath Diameter	Metallic Screen Diameter	Outer Sheath Diameter	Cable Weight	Packaging	Max DC Resistance at 20°C	Current Rating in air at 30°C	Current Rating in ground at 20°C	Short Circuit Current for 1s
mm ²	kV	mm	mm	mm	mm	mm	kg/km	m	Ω/km	A	A	kA
3x50	12/20	8.2	20.8	51	53	59	3984	1000	0.6410	159	140	4.7
3x70	12/20	9.8	21.9	54	55	62	4363	1000	0.4430	196	171	6.6
3x95	12/20	11.4	23.5	57	59	66	4967	1000	0.3200	238	204	9.0
3x120	12/20	13.1	25.2	61	63	69	5534	500	0.2530	274	232	11.3
3x150	12/20	14.1	26.2	63	65	72	5974	500	0.2060	309	259	14.2
3x185	12/20	15.9	28.0	67	68	76	6639	500	0.1640	354	293	17.5
3x240	12/20	18.2	30.3	72	74	81	7657	500	0.1250	415	338	22.7
3x300	12/20	20.5	32.6	77	78	86	8712	500	0.1000	472	380	28.3
3x50	18/30	8.2	25.7	62	64	70	5296	500	0.6410	159	140	4.7
3x70	18/30	9.8	26.8	64	66	73	5717	500	0.4430	196	171	6.6
3x95	18/30	11.4	28.4	68	70	77	6324	500	0.3200	238	204	9.0
3x120	18/30	13.1	30.1	72	73	81	7014	500	0.2530	274	232	11.3
3x150	18/30	14.1	31.1	74	75	83	7466	500	0.2060	309	259	14.2
3x185	18/30	15.9	32.9	77	79	87	8194	500	0.1640	354	293	17.5
3x240	18/30	18.2	35.2	83	84	93	9327	500	0.1250	415	338	22.7
3x300	18/30	20.5	37.5	87	89	98	10435	250	0.1000	472	380	28.3

Aluminium Cable - Lead Sheath XLPE Insulation

3.6/6(7.2) - 18/30(36) kV

3C AL/XLPE/CTS/LS/PVC- NA2XSEKY



CONSTRUCTION

Conductor	: Stranded Aluminium wire according to IEC 60228 - Class 2 for Circular Stranded Compacted
Conductor Screen	: Extruded Semi Conductive Compound
Insulation	: XLPE Compound
Insulation Screen	: Extruded Semi Conductive Compound
Metallic Screen	: Plain Annealed Copper Tapes
Filler	: PP Yarn Filler
Metallic Sheath	: Lead Alloy Sheath
Sheath	: PVC ST2 Compound

APPLICABLE STANDARDS

SNI IEC 60502-2, IEC 60502-2
IEC 60228
IEC 60332-1
IEC 60332-3-22
IEC 60332-3-23
IEC 60332-3-24

Design and Test Guidelines
Conductor
Flame Retardant
Flame Retardant Cat. A
Flame Retardant Cat. B
Flame Retardant Cat. C

Special features on request:
EPR Insulation
Flame Retardant Cat. A, B, C
Flame Retardant Non Category
Anti-termite

Anti-rodent
Oil Resistance
UV Resistance
Low Smoke Zero Halogen

IDENTIFICATIONS

Core Brown, Black, Grey

Others colours available upon request



IEC 60332-1
IEC 60332-3-22
IEC 60332-3-23
IEC 60332-3-24



Standard



Excellent



0°C



14 D

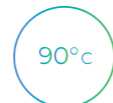

90°C
Normal
Operation
Temperature



250°C
Short
Circuit
Temperature

Dimension and Electrical Data

Cross Section	Tension U ₀ /U	Conductor Diameter	Insulation Diameter	Metallic Sheath Diameter	Outer Sheath Diameter	Cable Weight	Packaging	Max DC Resistance at 20°C	Current Rating in air at 30°C	Current Rating in ground at 20°C	Short Circuit Current for 1s
mm ²	kV	mm	mm	mm	mm	kg/km	m	Ω/km	A	A	kA
3x50	3.6/6	8.2	16	42	46	4375	1000	0.641	159	140	4.7
3x70	3.6/6	9.8	17	45	49	4954	1000	0.443	196	171	6.6
3x95	3.6/6	11.4	19	48	53	5800	500	0.320	238	204	9.0
3x120	3.6/6	13.1	21	52	57	6674	500	0.253	274	232	11.3
3x150	3.6/6	14.1	22	55	60	7363	500	0.206	309	259	14.2
3x185	3.6/6	15.9	23	59	64	8569	500	0.1640	354	293	17.5
3x240	3.6/6	18.2	26	64	70	10047	250	0.1250	415	338	22.7
3x300	3.6/6	20.5	28	69	76	11838	250	0.1000	472	380	28.3
3x50	6/10	8.2	17	43	48	4662	1000	0.641	159	140	4.7
3x70	6/10	9.8	18	46	51	5280	500	0.443	196	171	6.6
3x95	6/10	11.4	19	49	55	6127	500	0.320	238	204	9.0
3x120	6/10	13.1	21	53	59	7023	500	0.253	274	232	11.3
3x150	6/10	14.1	22	56	61	7926	500	0.206	309	259	14.2
3x185	6/10	15.9	24	60	66	8991	500	0.1640	354	293	17.5
3x240	6/10	18.2	26	65	71	10470	250	0.1250	415	338	22.7
3x300	6/10	20.5	28	70	77	12294	250	0.1000	472	380	28.3
3x50	8.7/15	8.2	19	48	53	5682	500	0.641	159	140	4.7
3x70	8.7/15	9.8	20	51	56	6357	500	0.443	196	171	6.6
3x95	8.7/15	11.4	22	55	60	7467	500	0.320	238	204	9.0
3x120	8.7/15	13.1	23	58	64	8448	500	0.253	274	232	11.3
3x150	8.7/15	14.1	24	61	67	8997	500	0.206	309	259	14.2
3x185	8.7/15	15.9	26	65	71	10089	250	0.1640	354	293	17.5
3x240	8.7/15	18.2	28	70	77	11922	250	0.1250	415	338	22.7
3x300	8.7/15	20.5	31	75	82	13586	250	0.1000	472	380	28.3

Dimension and Electrical Data (cont.)

Cross Section	Tension U _o /U	Conductor Diameter	Insulation Diameter	Metallic Sheath Diameter	Outer Sheath Diameter	Cable Weight	Packaging	Max DC Resistance at 20°C	Current Rating in air at 30°C	Current Rating in ground at 20°C	Short Circuit Current for 1s
mm ²	kV	mm	mm	mm	mm	kg/km	m	Ω/km	A	A	kA
3x50	12/20	8.2	21	53	58	6550	500	0.641	159	140	4.7
3x70	12/20	9.8	22	55	61	7438	500	0.443	196	171	6.6
3x95	12/20	11.4	24	59	65	8417	500	0.320	238	204	9.0
3x120	12/20	13.1	25	63	69	9483	500	0.253	274	232	11.3
3x150	12/20	14.1	26	65	72	10287	250	0.206	309	259	14.2
3x185	12/20	15.9	28	69	76	11448	250	0.1640	354	293	17.5
3x240	12/20	18.2	30	75	82	13121	250	0.1250	415	338	22.7
3x300	12/20	20.5	33	80	87	14812	250	0.1000	472	380	28.3
3x50	18/30	8.2	26	64	70	9532	500	0.641	159	140	4.7
3x70	18/30	9.8	27	67	73	10348	250	0.443	196	171	6.6
3x95	18/30	11.4	28	70	77	11478	250	0.320	238	204	9.0
3x120	18/30	13.1	30	74	81	12703	250	0.253	274	232	11.3
3x150	18/30	14.1	31	77	84	13618	250	0.206	309	259	14.2
3x185	18/30	15.9	33	81	88	14932	250	0.1640	354	293	17.5
3x240	18/30	18.2	35	86	94	17116	250	0.1250	415	338	22.7
3x300	18/30	20.5	38	91	99	19012	250	0.1000	472	380	28.3

Aluminium Cable - Lead Sheath XLPE Insulation

3.6/6(7.2) - 18/30(36) kV

1C AL/XLPE/CTS/LS/PVC/DATA/PVC – NA2XSKB(AL)Y

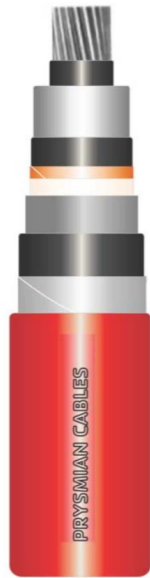

CONSTRUCTION

Conductor	: Stranded Aluminium wire according to IEC 60228 - Class 2 for Circular Stranded Compacted
Conductor Screen	: Extruded Semi Conductive Compound
Insulation	: XLPE Compound
Insulation Screen	: Extruded Semi Conductive Compound
Metallic Screen	: Plain Annealed Copper Tapes
Metallic Sheath	: Lead Alloy Sheath
Separation Sheath	: PVC Compound ST 2
Metallic Armour	: Double Aluminium Tapes
Sheath	: PVC Compound ST 2

APPLICABLE STANDARDS

SNI IEC 60502-2, IEC 60502-2
IEC 60228
IEC 60332-1
IEC 60332-3-22
IEC 60332-3-23
IEC 60332-3-24

Design and Test Guidelines
Conductor
Flame Retardant
Flame Retardant Cat. A
Flame Retardant Cat. B
Flame Retardant Cat. C

Special features on request:
EPR Insulation
Flame Retardant Cat. A, B, C
Flame Retardant Non Category
Anti-termites

Anti-rodent
Oil Resistance
UV Resistance
Low Smoke Zero Halogen

IDENTIFICATIONS

Core Not Applicable

Others colours available upon request



IEC 60332-1
IEC 60332-3-22
IEC 60332-3-23
IEC 60332-3-24



Standard



Excellent



0°C



14 D



Normal
Operation
Temperature



Short
Circuit
Temperature

Dimension and Electrical Data

Cross Section	Tension Uo/U	Conductor Diameter	Insulation Diameter	Metallic Screen Diameter	Metallic Sheath Diameter	Sep. Sheath Diameter	Armour Diameter	Outer Sheath Diameter	Cable Weight	Packaging	Max DC Resistance at 20°C	Current Rating in air at 30°C	Current Rating in ground at 20°C	Short Circuit Current for 1s
mm ²	kV	mm	mm	mm	mm	mm	mm	mm	kg/km	m	Ω/km	A	A	kA
1x50	3.6/6	8.2	16	18	22	25	27	30	2152	1000	0.641	184	152	4.7
1x70	3.6/6	9.8	17	19	23	26	28	32	2322	1000	0.443	230	186	6.6
1x95	3.6/6	11.4	19	20	24	27	30	34	2575	1000	0.320	280	221	9.0
1x120	3.6/6	13.1	21	22	26	29	32	35	2820	1000	0.253	324	252	11.3
1x150	3.6/6	14.1	22	23	27	30	33	37	3003	1000	0.206	368	281	14.2
1x185	3.6/6	15.9	23	25	29	32	34	38	3268	1000	0.164	424	317	17.5
1x240	3.6/6	18.2	26	27	31	34	37	41	3683	1000	0.125	502	367	22.7
1x300	3.6/6	20.5	28	29	33	36	39	43	4106	1000	0.100	577	414	28.3
1x400	3.6/6	22.9	30	32	36	39	41	46	4539	1000	0.0778	673	470	37.8
1x500	3.6/6	26.9	34	36	40	43	45	50	5447	500	0.0605	801	540	47.2
1x630	3.6/6	30.5	38	39	44	47	49	54	6454	500	0.0469	903	610	59.5
1x50	6/10	8.2	17	18	22	25	28	31	2213	1000	0.641	184	152	4.7
1x70	6/10	9.8	18	19	23	26	29	32	2385	1000	0.443	230	186	6.6
1x95	6/10	11.4	19	21	25	28	30	34	2624	1000	0.320	280	221	9.0
1x120	6/10	13.1	21	23	27	30	32	36	2886	1000	0.253	324	252	11.3
1x150	6/10	14.1	22	24	28	31	33	37	3053	1000	0.206	368	281	14.2
1x185	6/10	15.9	24	25	29	32	35	39	3337	1000	0.164	424	317	17.5
1x240	6/10	18.2	26	28	32	35	37	41	3755	1000	0.125	502	367	22.7
1x300	6/10	20.5	28	30	34	37	39	44	4180	1000	0.100	577	414	28.3
1x400	6/10	22.9	31	32	36	39	42	47	4667	1000	0.0778	673	470	37.8
1x500	6/10	26.9	35	36	40	43	46	51	5506	500	0.0605	787	537	47.2
1x630	6/10	30.5	38	40	44	47	50	55	6516	500	0.0469	903	610	59.5
1x50	8.7/15	8.2	19	20	24	27	30	33	2477	1000	0.6410	184	152	4.7
1x70	8.7/15	9.8	20	21	25	28	31	35	2638	1000	0.443	230	186	6.6
1x95	8.7/15	11.4	22	23	27	30	33	36	2899	1000	0.320	280	221	9.0
1x120	8.7/15	13.1	23	25	29	32	34	38	3168	1000	0.253	324	252	11.3
1x150	8.7/15	14.1	24	26	30	33	35	39	3339	1000	0.206	368	281	14.2
1x185	8.7/15	15.9	26	27	31	34	37	41	3630	1000	0.164	424	317	17.5
1x240	8.7/15	18.2	28	30	34	37	39	44	4057	1000	0.125	502	367	22.7
1x300	8.7/15	20.5	31	32	36	39	42	46	4470	1000	0.100	577	414	28.3
1x400	8.7/15	22.9	33	34	39	42	44	49	5129	500	0.0778	673	470	37.8
1x500	8.7/15	26.9	37	38	43	46	48	53	6003	500	0.0605	801	540	47.2
1x630	8.7/15	30.5	40	42	46	49	52	57	7048	500	0.0469	903	610	59.5

Dimension and Electrical Data (cont.)

Cross Section	Tension U ₀ /U	Conductor Diameter	Insulation Diameter	Metallic Screen Diameter	Metallic Sheath Diameter	Sep. Sheath Diameter	Armour Diameter	Outer Sheath Diameter	Cable Weight	Packaging	Max DC Resistance at 20°C	Current Rating in air at 30°C	Current Rating in ground at 20°C	Short Circuit Current for 1s
mm ²	kV	mm	mm	mm	mm	mm	mm	mm	kg/km	m	Ω/km	A	A	kA
1x50	3.6/6	8.2	21	22	26	29	32	36	2726	1000	0.641	184	152	4.7
1x70	3.6/6	9.8	22	23	27	30	33	37	2890	1000	0.443	230	186	6.6
1x95	3.6/6	11.4	24	25	29	32	35	39	3157	1000	0.320	280	221	9.0
1x120	3.6/6	13.1	25	27	31	34	36	40	3414	1000	0.253	324	252	11.3
1x150	3.6/6	14.1	26	28	32	35	37	41	3607	1000	0.206	368	281	14.2
1x185	3.6/6	15.9	28	29	33	36	39	43	3905	1000	0.164	424	317	17.5
1x240	3.6/6	18.2	30	32	36	39	41	46	4320	1000	0.125	502	367	22.7
1x300	3.6/6	20.5	33	34	38	41	44	48	4761	1000	0.100	577	414	28.3
1x400	3.6/6	22.9	35	36	41	44	46	51	5413	500	0.0778	673	470	37.8
1x500	3.6/6	26.9	39	40	45	48	so	55	6305	500	0.0605	801	540	47.2
1x630	3.6/6	30.5	42	44	48	51	54	59	7396	500	0.0469	903	610	59.5
1x50	6/10	8.2	26	27	31	34	37	41	3371	1000	0.641	184	152	4.7
1x70	6/10	9.8	27	28	32	35	38	42	3544	1000	0.443	230	186	6.6
1x95	6/10	11.4	28	30	34	37	39	44	3827	1000	0.320	280	221	9.0
1x120	6/10	13.1	30	32	36	39	41	46	4227	1000	0.253	324	252	11.3
1x150	6/10	14.1	31	33	37	40	42	47	4434	1000	0.206	368	281	14.2
1x185	6/10	15.9	33	34	39	42	44	49	4895	1000	0.164	424	317	17.5
1x240	6/10	18.2	35	37	41	44	47	51	5346	500	0.125	502	367	22.7
1x300	6/10	20.5	38	39	43	47	49	54	5979	500	0.100	577	414	28.3
1x400	6/10	22.9	40	41	46	49	52	57	6893	500	0.0778	673	470	37.8
1x500	6/10	26.9	44	45	so	53	56	62	7893	500	0.0605	801	540	47.2
1x630	6/10	30.5	47	49	54	57	60	66	9061	500	0.0469	903	610	59.5

Aluminium Cable - Lead Sheath XLPE Insulation

3.6/6(7.2) - 18/30(36) kV

3C AL/XLPE/CTS/LS/PVC/DSTA/PVC – NA2XSEKBY

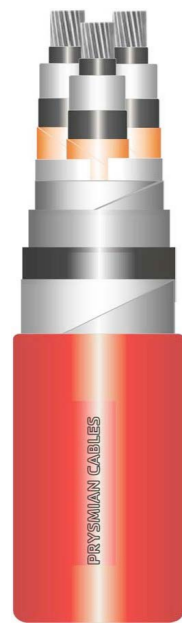

CONSTRUCTION

Conductor	: Stranded Aluminium wire according to IEC 60228 - Class 2 for Circular Stranded Compacted
Conductor Screen	: Extruded Semi Conductive Compound
Insulation	: XLPE Compound
Insulation Screen	: Extruded Semi Conductive Compound
Metallic Screen	: Plain Annealed Copper Tapes
Filler	: PP Yarn Filler
Metallic Sheath	: Lead Alloy Sheath
Separation Sheath	: PVC ST2 Compound
Metallic Armour	: Double Galvanized Steel Tapes
Sheath	: PVC ST2 Compound

APPLICABLE STANDARDS

SNI IEC 60502-2, IEC 60502-2
IEC 60228
IEC 60332-1
IEC 60332-3-22
IEC 60332-3-23
IEC 60332-3-24

Special features on request:
EPR Insulation
Flame Retardant Cat. A, B, C
Flame Retardant Non Category
Anti-termite

Design and Test Guidelines
Conductor
Flame Retardant
Flame Retardant Cat. A
Flame Retardant Cat. B
Flame Retardant Cat. C

Anti-rodent
Oil Resistance
UV Resistance
Low Smoke Zero Halogen

IDENTIFICATIONS

Core Brown, Black, Grey

Others colours available upon request



IEC 60332-1
IEC 60332-3-22
IEC 60332-3-23
IEC 60332-3-24



Standard



Excellent



0°C



14 D



90°C
Normal
Operation
Temperature



250°C
Short
Circuit
Temperature

Dimension and Electrical Data

Cross Section	Tension U ₀ /U	Conductor Diameter	Insulation Diameter	Metallic Sheath Diameter	Sep. Sheath Diameter	Armour Diameter	Outer Sheath Diameter	Cable Weight	Packaging	Max DC Resistance at 20°C	Current Rating in air at 30°C	Current Rating in ground at 20°C	Short Circuit Current for 1s
mm ²	kV	mm	mm	mm	mm	mm	mm	kg/km	m	Ω/km	A	A	kA
3x50	3.6/6	8.2	16	42	45	48	52	5544	500	0.387	205	181	7.2
3x70	3.6/6	9.8	17	45	48	50	55	6191	500	0.268	253	220	10.0
3x95	3.6/6	11.4	19	48	51	54	59	7107	500	0.193	307	263	13.6
3x120	3.6/6	13.1	21	52	55	58	63	8105	500	0.153	352	298	17.2
3x150	3.6/6	14.1	22	55	58	60	66	8855	500	0.124	397	332	21.5
3x185	3.6/6	15.9	23	59	62	64	70	10166	250	0.0991	453	374	26.5
3x240	3.6/6	18.2	26	64	67	70	76	11779	250	0.0754	529	431	34.3
3x300	3.6/6	20.5	28	69	72	76	83	14447	250	0.0601	599	482	42.9
3x50	6/10	8.2	17	43	46	49	54	5864	500	0.387	205	181	7.2
3x70	6/10	9.8	18	46	49	51	57	6551	500	0.268	253	220	10.0
3x95	6/10	11.4	19	49	52	55	61	7492	500	0.193	307	263	13.6
3x120	6/10	13.1	21	53	56	59	65	8485	500	0.153	352	298	17.2
3x150	6/10	14.1	22	56	59	61	67	9454	500	0.124	397	332	21.5
3x185	6/10	15.9	24	60	63	65	72	10588	250	0.0991	453	374	26.5
3x240	6/10	18.2	26	65	68	72	79	12973	250	0.0754	529	431	34.3
3x300	6/10	20.5	28	70	73	77	84	14944	250	0.0601	599	482	42.9
3x50	8.7/15	8.2	19	48	51	54	59	7012	500	0.387	205	181	7.2
3x70	8.7/15	9.8	20	51	54	56	62	7729	500	0.268	253	220	10.0
3x95	8.7/15	11.4	22	55	58	60	66	8965	500	0.193	307	263	13.6
3x120	8.7/15	13.1	23	59	62	64	70	10044	250	0.153	352	298	17.2
3x150	8.7/15	14.1	24	61	64	66	73	10649	250	0.124	397	332	21.5
3x185	8.7/15	15.9	26	65	68	72	79	12574	250	0.0991	453	374	26.5
3x240	8.7/15	18.2	28	70	73	77	84	14606	250	0.0754	529	431	34.3
3x300	8.7/15	20.5	31	75	78	82	90	16409	250	0.0601	599	482	42.9

Dimension and Electrical Data (cont)

Cross Section	Tension U ₀ /U	Conductor Diameter	Insulation Diameter	Metallic Sheath Diameter	Sep. Sheath Diameter	Armour Diameter	Outer Sheath Diameter	Cable Weight	Packaging	Max DC Resistance at 20°C	Current Rating in air at 30°C	Current Rating in ground at 20°C	Short Circuit Current for 1s
mm ²	kV	mm	mm	mm	mm	mm	mm	kg/km	m	Ω/km	A	A	kA
3x50	12/20	8.2	21	53	56	58	64	7994	500	0.387	205	181	7.2
3x70	12/20	9.8	22	55	58	61	67	8955	500	0.268	253	220	10.0
3x95	12/20	11.4	24	59	62	65	71	10027	250	0.193	307	263	13.6
3x120	12/20	13.1	25	63	66	69	75	11193	250	0.153	352	298	17.2
3x150	12/20	14.1	26	65	68	72	79	12765	250	0.124	397	332	21.5
3x185	12/20	15.9	28	69	72	76	83	14062	250	0.0991	453	374	26.5
3x240	12/20	18.2	30	75	78	82	89	15925	250	0.0754	529	431	34.3
3x300	12/20	20.5	33	80	83	87	95	17831	250	0.0601	599	482	42.9
3x50	18/30	8.2	26	64	67	70	76	11273	250	0.387	205	181	7.2
3x70	18/30	9.8	27	67	70	74	81	12912	250	0.268	253	220	10.0
3x95	18/30	11.4	28	71	74	78	85	14175	250	0.193	307	263	13.6
3x120	18/30	13.1	30	74	77	81	89	15498	250	0.153	352	298	17.2
3x150	18/30	14.1	31	77	80	84	91	16499	250	0.124	397	332	21.5
3x185	18/30	15.9	33	81	84	88	96	17995	250	0.0991	453	374	26.5
3x240	18/30	18.2	35	86	89	93	102	20375	250	0.0754	529	431	34.3
3x300	18/30	20.5	38	91	94	98	107	22447	250	0.0601	599	482	42.9

Aluminium Cable - Lead Sheath XLPE Insulation

3.6/6(7.2) - 18/30(36) kV

1C AL/XLPE/CTS/LS/PVC/AWA/PVC – NA2XSKYR(AL)Y



CONSTRUCTION

Conductor	: Stranded Aluminium wire according to IEC 60228 - Class 2 for Circular Stranded Compacted
Conductor Screen	: Extruded Semi Conductive Compound
Insulation	: XLPE Compound
Insulation Screen	: Extruded Semi Conductive Compound
Metallic Screen	: Plain Annealed Copper Tapes
Metallic Sheath	: Lead Alloy Sheath
Separation Sheath	: PVC ST2 Compound
Metallic Armour	: Aluminium Wires
Sheath	: PVC ST2 Compound

APPLICABLE STANDARDS

SNI IEC 60502-2, IEC 60502-2
IEC 60228
IEC 60332-1
IEC 60332-3-22
IEC 60332-3-23
IEC 60332-3-24

Design and Test Guidelines
Conductor
Flame Retardant
Flame Retardant Cat. A
Flame Retardant Cat. B
Flame Retardant Cat. C

Special features on request:
EPR Insulation
Flame Retardant Cat. A, B, C
Flame Retardant Non Category
Anti-termites

Anti-rodent
Oil Resistance
UV Resistance
Low Smoke Zero Halogen

IDENTIFICATIONS

Core Not Applicable

Others colours available upon request



IEC 60332-1
IEC 60332-3-22
IEC 60332-3-23
IEC 60332-3-24



Standard



Excellent



0°C



14 D



Normal
Operation
Temperature



Short
Circuit
Temperature

Dimension and Electrical Data

Cross Section	Tension U ₀ /U	Conductor Diameter	Insulation Diameter	Metallc Sheath Diameter	Sep. Sheath Diameter	Armour Diameter	Outer Sheath Diameter	Cable Weight	Packaging	Max DC Resistance at 20°C	Current Rating in air at 30°C	Current Rating in ground at 20°C	Short Circuit Current for 1s
mm ²	kV	mm	mm	mm	mm	mm	mm	kg/km	m	Ω/km	A	A	kA
1x50	3.6/6	8.2	16	22	25	28	31	2328	1000	0.6410	184	152	4.7
1x70	3.6/6	9.8	17	23	26	29	32	2491	1000	0.4430	230	186	6.6
1x95	3.6/6	11.4	19	24	27	32	35	2836	1000	0.3200	280	221	9.0
1x120	3.6/6	13.1	21	26	29	33	37	3112	1000	0.2530	324	252	11.3
1x150	3.6/6	14.1	22	27	30	34	38	3293	1000	0.2060	368	281	14.2
1x185	3.6/6	15.9	23	29	32	36	40	3591	1000	0.1640	424	317	17.5
1x240	3.6/6	18.2	26	31	34	38	43	4030	1000	0.1250	502	367	22.7
1x300	3.6/6	20.5	28	33	36	42	46	4609	1000	0.1000	577	414	28.3
1x400	3.6/6	22.9	30	36	39	44	48	5083	500	0.0778	673	470	37.8
1x500	3.6/6	26.9	34	40	43	48	53	6045	500	0.0605	801	540	47.2
1x630	3.6/6	30.5	38	44	47	52	57	7116	500	0.0469	903	610	59.5
1x50	6/10	8.2	17	22	25	28	32	2373	1000	0.6410	184	152	4.7
1x70	6/10	9.8	18	23	26	30	34	2633	1000	0.4430	230	186	6.6
1x95	6/10	11.4	19	25	28	32	36	2912	1000	0.3200	280	221	9.0
1x120	6/10	13.1	21	27	30	34	37	3169	1000	0.2530	324	252	11.3
1x150	6/10	14.1	22	28	31	35	39	3363	1000	0.2060	368	281	14.2
1x185	6/10	15.9	24	29	32	36	41	3673	1000	0.1640	424	317	17.5
1x240	6/10	18.2	26	32	35	39	43	4090	1000	0.1250	502	367	22.7
1x300	6/10	20.5	28	34	37	42	47	4702	1000	0.1000	577	414	28.3
1x400	6/10	22.9	31	36	39	44	49	5228	500	0.0778	673	470	37.8
1x500	6/10	26.9	35	40	43	48	53	6117	500	0.0605	801	540	47.2
1x630	6/10	30.5	38	44	47	52	57	7178	500	0.0469	903	610	59.5
1x50	8.7/15	8.2	19	24	27	31	35	2759	1000	0.6410	184	152	4.7
1x70	8.7/15	9.8	20	25	28	32	36	2924	1000	0.4430	230	186	6.6
1x95	8.7/15	11.4	22	27	30	34	38	3210	1000	0.3200	280	221	9.0
1x120	8.7/15	13.1	23	29	32	36	40	3474	1000	0.2530	324	252	11.3
1x150	8.7/15	14.1	24	30	33	37	41	3672	1000	0.2060	368	281	14.2
1x185	8.7/15	15.9	26	31	34	38	43	3966	1000	0.1640	424	317	17.5
1x240	8.7/15	18.2	28	34	37	42	47	4579	1000	0.1250	502	367	22.7
1x300	8.7/15	20.5	31	36	39	44	49	5012	500	0.1000	577	414	28.3
1x400	8.7/15	22.9	33	39	42	47	52	5717	500	0.0778	673	470	37.8
1x500	8.7/15	26.9	37	43	46	51	56	6641	500	0.0605	801	540	47.2
1x630	8.7/15	30.5	40	46	49	55	60	7752	500	0.0469	903	610	59.5

Dimension and Electrical Data (cont.)

Cross Section	Tension U ₀ /U	Conductor Diameter	Insulation Diameter	Metallic Sheath Diameter	Sep. Sheath Diameter	Armour Diameter	Outer Sheath Diameter	Cable Weight	Packaging	Max DC Resistance at 20°C	Current Rating in air at 30°C	Current Rating in ground at 20°C	Short Circuit Current for 1s
mm ²	kV	mm	mm	mm	mm	mm	mm	kg/km	m	Ω/km	A	A	kA
1x50	12/20	8.2	21	26	29	33	37	3002	1000	0.6410	184	152	4.7
1x70	12/20	9.8	22	27	30	34	38	3201	1000	0.4430	230	186	6.6
1x95	12/20	11.4	24	29	32	36	40	3485	1000	0.3200	280	221	9.0
1x120	12/20	13.1	25	31	34	38	42	3762	1000	0.2530	324	252	11.3
1x150	12/20	14.1	26	32	35	40	44	4088	1000	0.2060	368	281	14.2
1x185	12/20	15.9	28	33	36	41	46	4414	1000	0.1640	424	317	17.5
1x240	12/20	18.2	30	36	39	44	48	4863	1000	0.1250	502	367	22.7
1x300	12/20	20.5	33	38	41	46	51	5331	500	0.1000	577	414	28.3
1x400	12/20	22.9	35	41	44	49	54	6023	500	0.0778	673	470	37.8
1x500	12/20	26.9	39	45	48	53	58	6979	500	0.0605	801	540	47.2
1x630	12/20	30.5	42	48	51	57	62	8129	500	0.0469	903	610	59.5
1x50	18/30	8.2	26	31	34	38	42	3699	1000	0.6410	184	152	4.7
1x70	18/30	9.8	27	32	35	40	45	4038	1000	0.4430	230	186	6.6
1x95	18/30	11.4	28	34	37	42	47	4348	1000	0.3200	280	221	9.0
1x120	18/30	13.1	30	36	39	44	48	4770	1000	0.2530	324	252	11.3
1x150	18/30	14.1	31	37	40	45	50	4994	1000	0.2060	368	281	14.2
1x185	18/30	15.9	33	39	42	47	52	5482	500	0.1640	424	317	17.5
1x240	18/30	18.2	35	41	44	49	54	5968	500	0.1250	502	367	22.7
1x300	18/30	20.5	38	43	47	52	57	6628	500	0.1000	577	414	28.3
1x400	18/30	22.9	40	46	49	54	60	7590	500	0.0778	673	470	37.8
1x500	18/30	26.9	44	50	53	58	64	8656	500	0.0605	801	540	47.2
1x630	18/30	30.5	47	54	57	62	68	9877	500	0.0469	903	610	59.5

Aluminium Cable - Lead Sheath XLPE Insulation

3.6/6(7.2) - 18/30(36) kV

3C AL/XLPE/CTS/LS/PVC/SWA/PVC – NA2XSEKRY



CONSTRUCTION

Conductor	: Stranded Aluminium wire according to IEC 60228 - Class 2 for Circular Stranded Compacted
Conductor Screen	: Extruded Semi Conductive Compound
Insulation	: XLPE Compound
Insulation Screen	: Extruded Semi Conductive Compound
Metallic Screen	: Plain Annealed Copper Tapes
Filler	: PP Yarn Filler
Metallic Sheath	: Lead Alloy Sheath
Separation Sheath	: PVC ST2 Compound
Metallic Armour	: Galvanized Steel Wires
Sheath	: PVC ST2 Compound

APPLICABLE STANDARDS

SNI IEC 60502-2, IEC 60502-2
IEC 60228
IEC 60332-1
IEC 60332-3-22
IEC 60332-3-23
IEC 60332-3-24

Special features on request:
EPR Insulation
Flame Retardant Cat. A, B, C
Flame Retardant Non Category
Anti-termite

Design and Test Guidelines
Conductor
Flame Retardant
Flame Retardant Cat. A
Flame Retardant Cat. B
Flame Retardant Cat. C

Anti-rodent
Oil Resistance
UV Resistance
Low Smoke Zero Halogen

IDENTIFICATIONS

Core Brown, Black, Grey

Others colours available upon request



IEC 60332-1
IEC 60332-3-22
IEC 60332-3-23
IEC 60332-3-24



Standard



Excellent



0°C

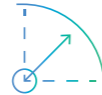

14 D



90°C
Normal Operation Temperature



250°C
Short Circuit Temperature

Dimension and Electrical Data

Cross Section	Tension U ₀ /U	Conductor Diameter	Insulation Diameter	Metallic Sheath Diameter	Sep. Sheath Diameter	Armour Diameter	Outer Sheath Diameter	Cable Weight	Packaging	Max DC Resistance at 20°C	Current Rating in air at 30°C	Current Rating in ground at 20°C	Short Circuit Current for 1s
mm ²	kV	mm	mm	mm	mm	mm	mm	kg/km	m	Ω/km	A	A	kA
3x50	3.6/6	8.2	16	42	45	50	56	6940	500	0.6410	159	140	4.7
3x70	3.6/6	9.8	17	45	48	53	59	7668	500	0.4430	196	171	6.6
3x95	3.6/6	11.4	19	48	51	56	63	8716	500	0.320	238	204	9.0
3x120	3.6/6	13.1	21	52	55	60	67	9788	500	0.2530	274	232	11.3
3x150	3.6/6	14.1	22	55	58	63	69	10582	250	0.2060	309	259	14.2
3x185	3.6/6	15.9	23	59	62	68	75	12836	250	0.1640	354	293	17.5
3x240	3.6/6	18.2	26	64	67	73	81	14690	250	0.1250	415	338	22.7
3x300	3.6/6	20.5	28	69	72	79	86	16794	250	0.1000	472	380	28.3
3x50	6/10	8.2	17	43	46	51	57	7311	500	0.6410	159	140	4.7
3x70	6/10	9.8	18	46	49	54	60	8055	500	0.4430	196	171	6.6
3x95	6/10	11.4	19	49	52	58	64	9099	500	0.320	238	204	9.0
3x120	6/10	13.1	21	53	56	61	68	10225	250	0.2530	274	232	11.3
3x150	6/10	14.1	22	56	59	65	72	12042	250	0.2060	309	259	14.2
3x185	6/10	15.9	24	60	63	69	76	13309	250	0.1640	354	293	17.5
3x240	6/10	18.2	26	65	68	74	82	15194	250	0.1250	415	338	22.7
3x300	6/10	20.5	28	70	73	80	88	17330	250	0.1000	472	380	28.3
3x50	8.7/15	8.2	19	48	51	56	63	8586	500	0.6410	159	140	4.7
3x70	8.7/15	9.8	20	51	54	59	65	9385	500	0.4430	196	171	6.6
3x95	8.7/15	11.4	22	55	58	64	71	11508	250	0.320	238	204	9.0
3x120	8.7/15	13.1	23	59	62	68	75	12720	250	0.2530	274	232	11.3
3x150	8.7/15	14.1	24	61	64	70	78	13421	250	0.2060	309	259	14.2
3x185	8.7/15	15.9	26	65	68	74	82	14744	250	0.1640	354	293	17.5
3x240	8.7/15	18.2	28	70	73	80	88	16956	250	0.1250	415	338	22.7
3x300	8.7/15	20.5	31	75	78	85	93	18930	250	0.1000	472	380	28.3

Dimension and Electrical Data (cont.)

Cross Section	Tension U ₀ /U	Conductor Diameter	Insulation Diameter	Metallic Sheath Diameter	Sep. Sheath Diameter	Armour Diameter	Outer Sheath Diameter	Cable Weight	Packaging	Max DC Resistance at 20°C	Current Rating in air at 30°C	Current Rating in ground at 20°C	Short Circuit Current for 1s
mm ²	kV	mm	mm	mm	mm	mm	mm	kg/km	m	Ω/km	A	A	kA
3x50	3.6/6	8.2	21	53	56	61	67	9674	500	0.6410	159	140	4.7
3x70	3.6/6	9.8	22	55	58	65	72	11486	250	0.4430	196	171	6.6
3x95	3.6/6	11.4	24	59	62	69	76	12695	250	0.320	238	204	9.0
3x120	3.6/6	13.1	25	63	66	72	80	14059	250	0.2530	274	232	11.3
3x150	3.6/6	14.1	26	65	68	75	83	15019	250	0.2060	309	259	14.2
3x185	3.6/6	15.9	28	69	72	79	87	16410	250	0.1640	354	293	17.5
3x240	3.6/6	18.2	30	75	78	84	92	18460	250	0.1250	415	338	22.7
3x300	3.6/6	20.5	33	80	83	89	98	20455	250	0.1000	472	380	28.3
3x50	6/10	8.2	26	64	67	74	81	14184	250	0.6410	159	140	4.7
3x70	6/10	9.8	27	67	70	76	84	15156	250	0.4430	196	171	6.6
3x95	6/10	11.4	28	71	74	80	88	16557	250	0.320	238	204	9.0
3x120	6/10	13.1	30	74	77	84	92	18039	250	0.2530	274	232	11.3
3x150	6/10	14.1	31	77	80	86	95	19110	250	0.2060	309	259	14.2
3x185	6/10	15.9	33	81	84	90	99	20656	250	0.1640	354	293	17.5
3x240	6/10	18.2	35	86	89	96	105	23217	200	0.1250	415	338	22.7
3x300	6/10	20.5	38	91	94	101	110	25468	200	0.1000	472	380	28.3

Aluminium Cable - Lead Sheath XLPE Insulation

3.6/6(7.2) - 18/30(36) kV

3C AL/XLPE/CTS/LS/PVC/SFA/PVC – NA2XSEKFY



CONSTRUCTION

Conductor	: Stranded Aluminium wire according to IEC 60228 - Class 2 for Circular Stranded Compacted
Conductor Screen	: Extruded Semi Conductive Compound
Insulation	: XLPE Compound
Insulation Screen	: Extruded Semi Conductive Compound
Metallic Screen	: Plain Annealed Copper Tapes
Filler	: PP Yarn Filler
Metallic Sheath	: Lead Alloy Sheath
Separation Sheath	: PVC ST2 Compound
Metallic Armour	: Galvanized Steel Flat Armour
Sheath	: PVC ST2 Compound

APPLICABLE STANDARDS

SNI IEC 60502-2, IEC 60502-2
IEC 60228
IEC 60332-1
IEC 60332-3-22
IEC 60332-3-23
IEC 60332-3-24

Special features on request:
EPR Insulation
Flame Retardant Cat. A, B, C
Flame Retardant Non Category
Anti-termite

Design and Test Guidelines
Conductor
Flame Retardant
Flame Retardant Cat. A
Flame Retardant Cat. B
Flame Retardant Cat. C

Anti-rodent
Oil Resistance
UV Resistance
Low Smoke Zero Halogen

IDENTIFICATIONS

Core Brown, Black, Grey

Others colours available upon request



IEC 60332-1
IEC 60332-3-22
IEC 60332-3-23
IEC 60332-3-24



Standard



Excellent



0°C



14 D



Normal
Operation
Temperature



Short
Circuit
Temperature

Dimension and Electrical Data

Cross Section	Tension U ₀ /U	Conductor Diameter	Insulation Diameter	Metallic Sheath Diameter	Sep. Sheath Diameter	Armour Diameter	Outer Sheath Diameter	Cable Weight	Packaging	Max DC Resistance at 20°C	Current Rating in air at 30°C	Current Rating in ground at 20°C	Short Circuit Current for 1s
mm ²	kV	mm	mm	mm	mm	mm	mm	kg/km	m	Ω/km	A	A	kA
3x50	3.6/6	8.2	16	42	45	47	52	5599	500	0.6410	159	140	4.7
3x70	3.6/6	9.8	17	44	48	49	55	6251	500	0.4430	196	171	6.6
3x95	3.6/6	11.4	19	48	51	53	59	7209	500	0.320	238	204	9.0
3x120	3.6/6	13.1	21	52	55	57	63	8192	500	0.2530	274	232	11.3
3x150	3.6/6	14.1	22	54	58	59	66	8929	500	0.2060	309	259	14.2
3x185	3.6/6	15.9	23	58	62	63	70	10245	250	0.1640	354	293	17.5
3x240	3.6/6	18.2	26	64	67	69	76	11871	250	0.1250	415	338	22.7
3x300	3.6/6	20.5	28	69	72	74	81	13809	250	0.1000	472	380	28.3
3x50	6/10	8.2	17	43	46	48	53	5923	500	0.6410	159	140	4.7
3x70	6/10	9.8	18	45	49	50	56	6617	500	0.4430	196	171	6.6
3x95	6/10	11.4	19	49	52	54	60	7573	500	0.320	238	204	9.0
3x120	6/10	13.1	21	53	56	58	64	8553	500	0.2530	274	232	11.3
3x150	6/10	14.1	22	56	59	60	67	9562	500	0.2060	309	259	14.2
3x185	6/10	15.9	24	60	63	64	71	10706	250	0.1640	354	293	17.5
3x240	6/10	18.2	26	65	68	70	77	12367	250	0.1250	415	338	22.7
3x300	6/10	20.5	28	70	73	75	82	14302	250	0.1000	472	380	28.3
3x50	8.7/15	8.2	19	48	51	53	59	7116	500	0.6410	159	140	4.7
3x70	8.7/15	9.8	20	51	54	55	62	7842	500	0.4430	196	171	6.6
3x95	8.7/15	11.4	22	54	58	59	66	9034	500	0.320	238	204	9.0
3x120	8.7/15	13.1	23	58	61	63	70	10125	250	0.2530	274	232	11.3
3x150	8.7/15	14.1	24	61	64	65	72	10745	250	0.2060	309	259	14.2
3x185	8.7/15	15.9	26	64	68	69	77	11980	250	0.1640	354	293	17.5
3x240	8.7/15	18.2	28	70	73	75	82	13905	250	0.1250	415	338	22.7
3x300	8.7/15	20.5	31	75	78	80	88	15714	250	0.1000	472	380	28.3

Dimension and Electrical Data (cont.)

Cross Section	Tension U _o /U	Conductor Diameter	Insulation Diameter	Metallic Sheath Diameter	Sep. Sheath Diameter	Armour Diameter	Outer Sheath Diameter	Cable Weight	Packaging	Max DC Resistance at 20°C	Current Rating in air at 30°C	Current Rating in ground at 20°C	Short Circuit Current for 1s
mm ²	kV	mm	mm	mm	mm	mm	mm	kg/km	m	Ω/km	A	A	kA
3x50	3.6/6	8.2	21	52	55	57	64	8074	500	0.6410	159	140	4.7
3x70	3.6/6	9.8	22	55	58	60	67	9038	500	0.4430	196	171	6.6
3x95	3.6/6	11.4	24	59	62	64	71	10159	250	0.320	238	204	9.0
3x120	3.6/6	13.1	25	63	66	68	75	11277	250	0.2530	274	232	11.3
3x150	3.6/6	14.1	26	65	68	70	77	12152	250	0.2060	309	259	14.2
3x185	3.6/6	15.9	28	69	72	74	81	13421	250	0.1640	354	293	17.5
3x240	3.6/6	18.2	30	74	77	79	87	15245	250	0.1250	415	338	22.7
3x300	3.6/6	20.5	33	79	82	84	93	17095	250	0.1000	472	380	28.3
3x50	6/10	8.2	26	64	67	69	76	11360	250	0.6410	159	140	4.7
3x70	6/10	9.8	27	67	70	71	79	12287	250	0.4430	196	171	6.6
3x95	6/10	11.4	28	70	73	75	83	13525	250	0.320	238	204	9.0
3x120	6/10	13.1	30	74	77	79	87	14797	250	0.2530	274	232	11.3
3x150	6/10	14.1	31	77	80	81	90	15784	250	0.2060	309	259	14.2
3x185	6/10	15.9	33	80	84	85	94	17250	250	0.1640	354	293	17.5
3x240	6/10	18.2	35	86	89	91	100	19584	250	0.1250	415	338	22.7
3x300	6/10	20.5	38	91	94	96	105	21599	250	0.1000	472	380	28.3

AIR BAG™ Cable System

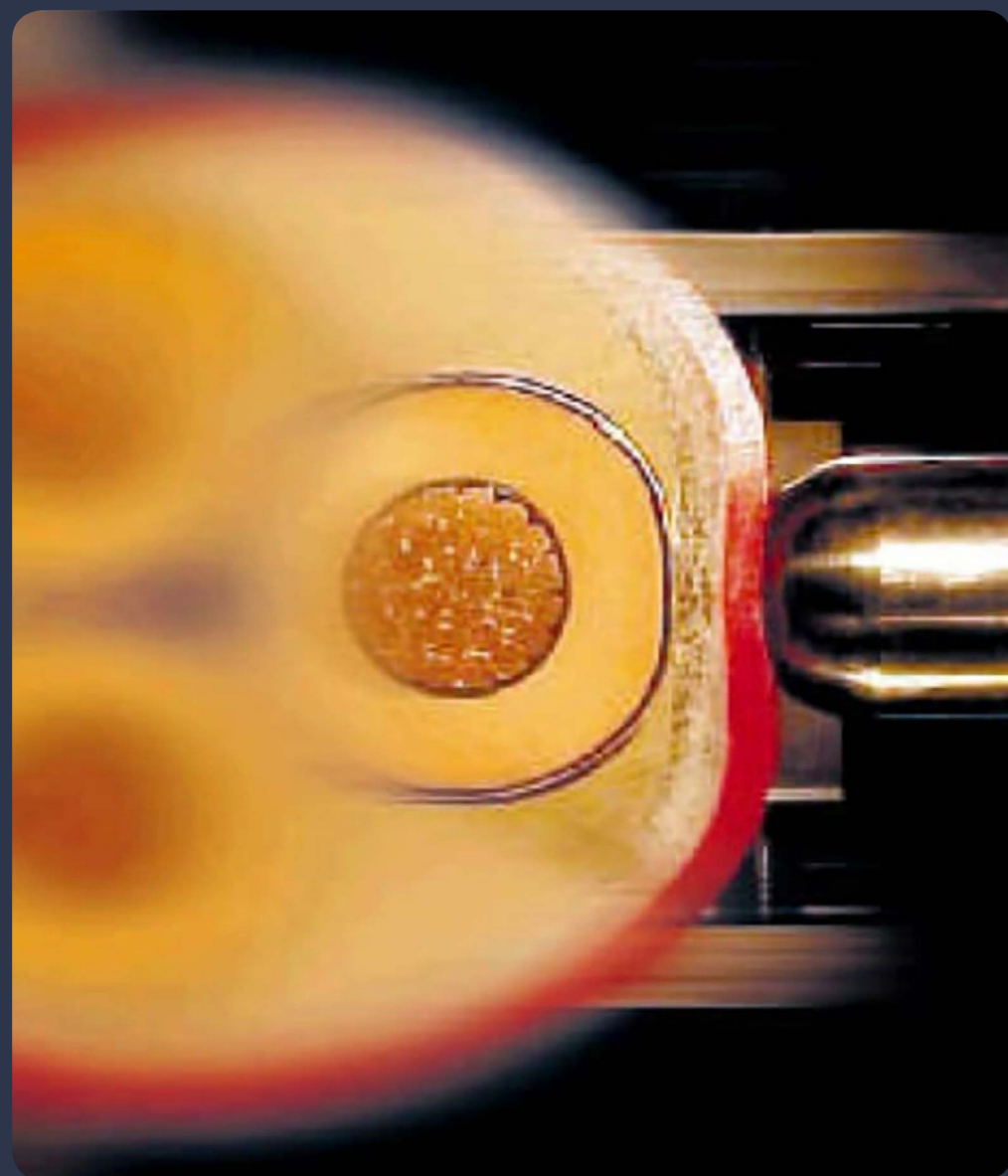

A revolutionary system for energy cables

Prysmian has designed and patented a revolutionary solution that provides better mechanical protection than traditional metal armoured cable maintaining the functional advantages of unarmoured cables. AIR BAG™ is a radically new design that absorbs the kinetic energy of a shock by its deformation. In this way no residual energy is left to damage the “sensitive” parts of the cable such as insulation and screens. Metal armouring doesn’t behave so efficiently: part of the energy of a shock is transmitted to the inner layers of the cable, potentially prejudicing the insulation’s integrity.

The level of protection achieved with AIR BAG™ and, by consequence, the reliability is substantially improved. Additionally, the cable is much lighter, flexible and easy to install than a traditional armoured cable. Thanks to AIR BAG™ versatility the range of applications is wide and covers residential, infrastructures, industry and utilities, always giving the same benefits in terms of reliability and weight reduction.

Protection Against Mechanical Damage

Cables can be damaged in many different circumstances and in virtually all operative environments mechanical abuse can often damage cable insulation and protective screens, leading to a premature and unexpected failure and, in any case, to a dramatic decrease of long term reliability. The economic consequences of this and the disruptive effects on service continuity are easy to quantify.

Industry’s response has been traditionally to protect cables with metal armouring (Applied in tapes, wires, etc) or to install them with additional external protection such as covered trays, pipes etc. Both solutions involve significant additional costs and longer installation time. In particular the traditional metal armoured cables show a significant disadvantage in terms of weight, flexibility, difficult jointing compared to a standard unarmoured cable.



Design

The AIR BAG™ system is a mechanical protection that can be applied to multicore and single core cables. Depending on specific applications different architectures are possible. The polymeric extruded layers work together as a system and provide a very effective defence against impact.

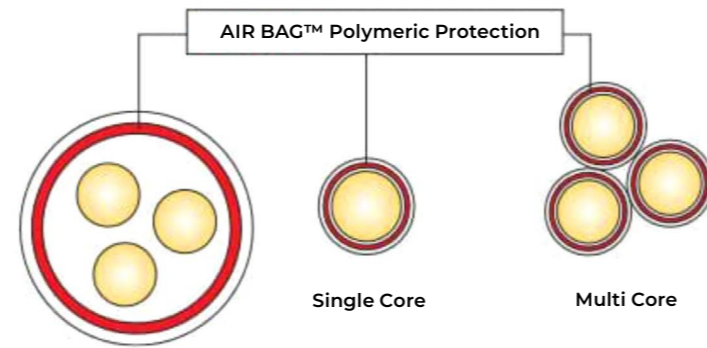

How It Works

Test device: French specification for extruded HV cables (Spec. HN 33-S-52 cl.5.3.2.1)



250 Joule impact on cable

Metal Armoured

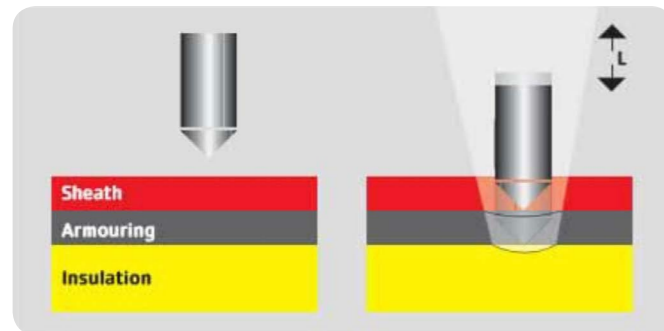

Metal armour has a much higher modulus, thus impact energy is dissipated with deformation (L) and a high dangerous specific force is transmitted to inner layers of the cable.



Typical metal armouring would caused permanent deformation that would damage the cable inner layer.

AIR BAG™

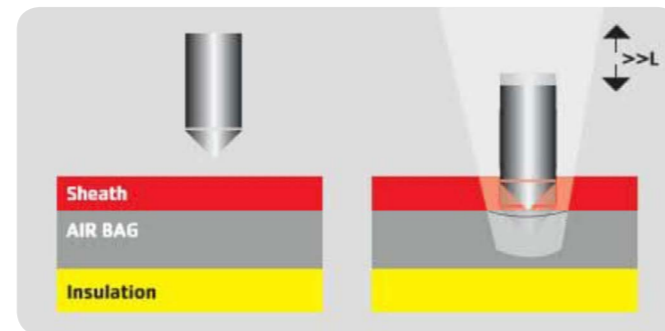

AIR BAG™ acts as a shock absorber.



AIR BAG™ special extruded layers able to absorb the impact energy and reduce any further damage to cable inner layer.

Impact Test

Steel Tape Armoured

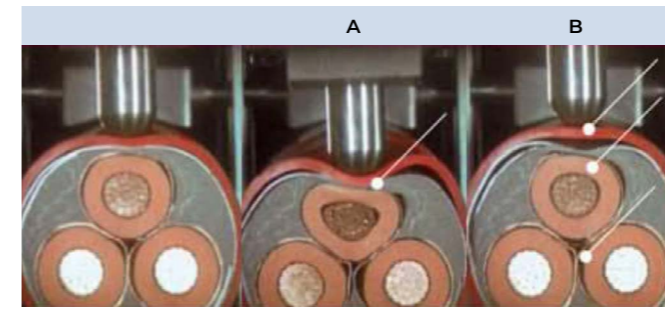

70 Joule impact at 2000 frame/second.

Picture taken with high speed camera in Prysmian R&D labs by the "Politecnico di Milano" University, Milan, Italy.

20kV 3x150mm² Copper Conductor, EPR Insulation.

AIR BAG™

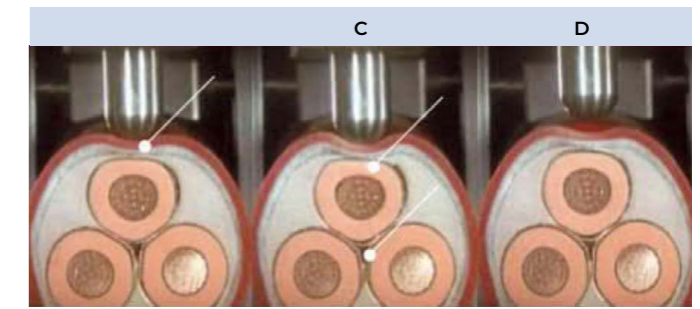

A. Steel tape armour shows high deformation concentrated in a small area
B. Due to permanent deformation of metal armoured, cable cores cannot recover initial shape, insulation of conductor is permanently damaged, copper screens have been badly detached.
C. AIR BAG™ acts like a shock absorber.
D. AIR BAG™ avoid core damage

A closer look on the impact test towards the metal armour cable versus AIR BAG™ cable:

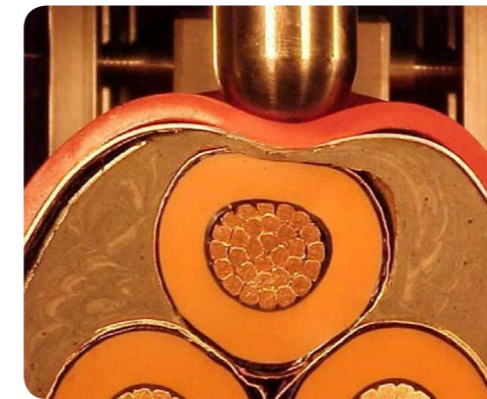

Armoured Cable
 3x150mm² Cu - 12/20kV
 Impact = 70 J

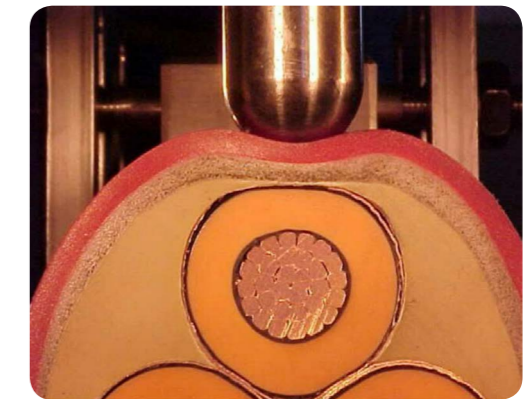

AIR BAG™ Cable
 3x150mm² Cu - 12/20kV
 Impact = 70 J

Comparison Against Metal Armoured Cable Types

Steel Tape Armoured 3x300mm²

Cable type: RE4H10RNR - 22kV

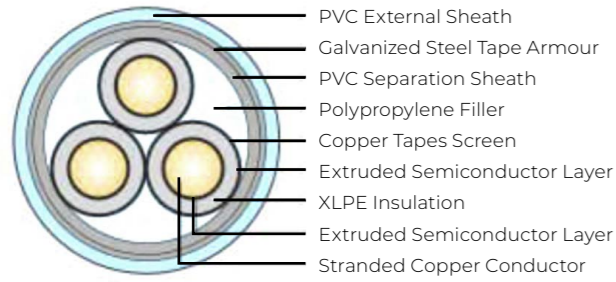

AIR BAG™ 3x300mm²

Cable type: RE4H10(AR)E - 22kV

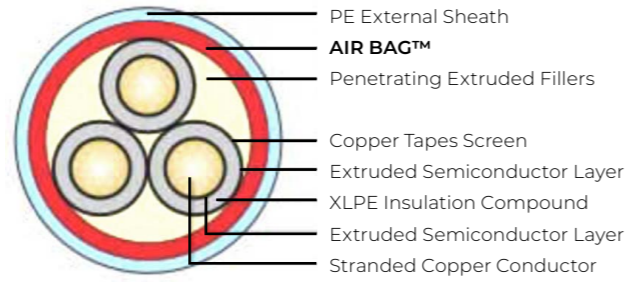

	Steel Tape Armoured	AIR BAG™	Delta
Cable weight - kg/m	15.5	13	-16%
Standard Reel Length - m	250	300	+20%

Steel Tape Armoured 3x185mm²

Cable type: RE4H10LRNR - 11kV

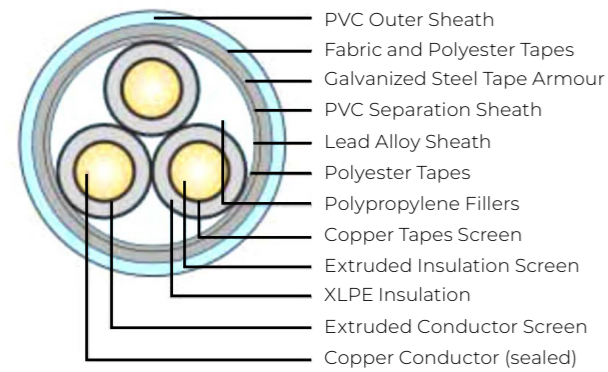

AIR BAG™ - HEPR Insulation 3x185mm²

Cable type: RG7H10(AR)E - 11kV

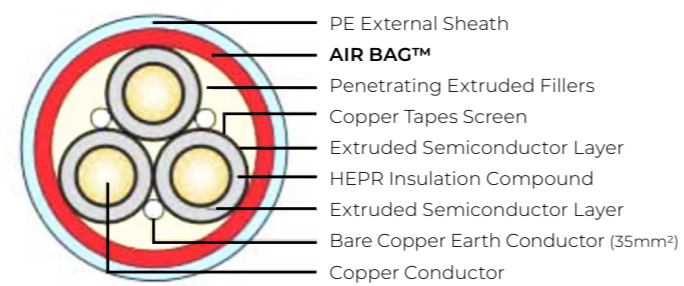

	Steel Tape Armoured	AIR BAG™	Delta
Cable weight - kg/m	18.6	10.6	-43%
Standard Reel Length - m	250.0	450.0	+80%

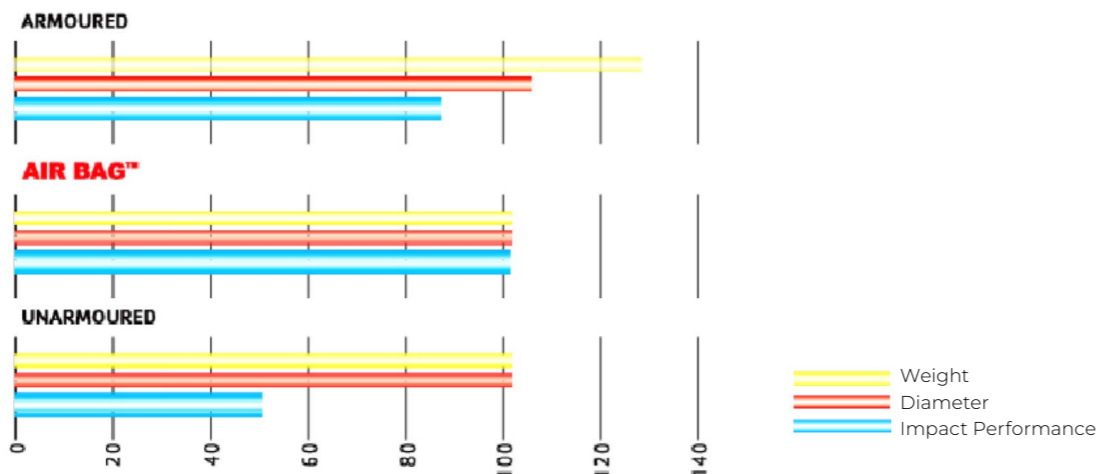

Benefits

VS ARMoured CABLE

- Better impact performance
- Reduced diameter
- Lower in weight
- Longer cable length on standard drums
- Same Fire Performances
- Same resistance to oils/chemicals
- Same resistance to effects of water
- Easier installation/spliceability
- Lower sensitivity to ground stray currents and harmonics
- Lower screen/armour losses

Replaces traditional metal armour, providing better impact performances, with lightness and ease of installation typical of unarmoured cables.

VS UNARMoured CABLE

- Double impact performance
- Diameter – no significant variation
- Same flexibility
- Same Fire Performances
- Same resistance to oils/chemicals
- Same resistance to effects of water
- Same ease of installation

Gives a dramatic improvement in mechanical resistance, with no significant variation in terms of weight and rigidity.

Accessories



The AIR BAG™ range is fully compatible with traditional joints and terminations. The installation procedures are the same as for traditional accessories.

AIR BAG™ Polymeric Armored Cable

3.6/6(7.2) - 18/30(36) kV

1C CU/XLPE/CTS/AB/PVC



CONSTRUCTION

Conductor	: Plain annealed copper wire according to IEC 60228 - Class 2 for Stranded Compacted Conductors
Conductor Screen	: Extruded Semi Conductive Compound
Insulation	: XLPE Compound
Insulation Screen	: Extruded Semi Conductive Compound
Metallic Screen	: Plain Annealed Copper Tapes
Non Metallic Armour	: AB HPA High grade Polymeric Armor
Sheath	: PVC Compound ST 2

APPLICABLE STANDARDS

SNI IEC 60502-2, IEC 60502-2
IEC 60228
IEC 60332-1
IEC 60332-3-24

Special features on request:
EPR Insulation
Flame Retardant Cat. A, B, C
Flame Retardant Non Category
Anti-termites
Anti-rodent

Design and Test Guidelines
Conductor
Flame Retardant
Flame Retardant Cat. C

Oil Resistance
UV Resistance
Low Smoke Zero Halogen
PE ST7

IDENTIFICATIONS

Core Not Applicable



IEC 60332-1
IEC 60332-3-24



Standard



Excellent



0°C



12 D



Normal
Operation
Temperature



Short
Circuit
Temperature

Dimension and Electrical Data

Cross Section	Tension U ₀ /U	Conductor Diameter	Insulation Diameter	Non Metallic Armour Diameter	Outer Sheath Diameter	Cable Weight	Packaging	Max DC Resistance at 20°C	Current Rating in air at 30°C	Current Rating in ground at 20°C	Short Circuit Current for 1s
mm ²	kV	mm	mm	mm	mm	kg/km	m	Ω/km	A	A	kA
1x35	3.6/6	7.0	14.5	22	25	757	1000	0.5240	194	165	5.0
1x50	3.6/6	8.2	15.5	23	26	882	1000	0.3870	238	196	7.2
1x70	3.6/6	9.8	17.0	24	27	1100	1000	0.2680	296	239	10.0
1x95	3.6/6	11.3	18.5	25	28	1356	1000	0.1930	361	285	13.6
1x120	3.6/6	12.8	20.0	27	30	1603	1000	0.1530	417	323	17.2
1x150	3.6/6	14.2	21.0	28	31	1882	1000	0.1240	473	361	21.5
1x185	3.6/6	15.7	22.5	30	33	2249	1000	0.0991	543	406	26.5
1x240	3.6/6	18.2	25.0	32	35	2802	1000	0.0754	641	469	34.3
1x300	3.6/6	20.4	27.5	34	38	3420	1000	0.0601	718	525	42.9
1x400	3.6/6	22.8	30.0	37	40	4261	1000	0.0470	845	590	57.2
1x500	3.6/6	26.1	33.5	41	44	5316	500	0.0366	972	675	71.5
1x630	3.6/6	29.9	37.5	45	49	6809	500	0.0283	1078	734	90.1
1x35	6/10	7.0	15.0	22	25	771	1000	0.5240	194	165	5.0
1x50	6/10	8.2	16.0	23	26	897	1000	0.3870	238	196	7.2
1x70	6/10	9.8	17.5	25	28	1117	1000	0.2680	296	239	10.0
1x95	6/10	11.3	19.0	26	29	1390	1000	0.1930	361	285	13.6
1x120	6/10	12.8	20.5	28	31	1640	1000	0.1530	417	323	17.2
1x150	6/10	14.2	22.0	29	32	1934	1000	0.1240	473	361	21.5
1x185	6/10	15.7	23.5	31	34	2289	1000	0.0991	543	406	26.5
1x240	6/10	18.2	26.0	33	36	2862	1000	0.0754	641	469	34.3
1x300	6/10	20.4	28.0	35	39	3484	1000	0.0601	718	525	42.9
1x400	6/10	22.8	30.5	38	41	4319	1000	0.0470	845	590	57.2
1x500	6/10	26.1	34.0	41	45	5364	500	0.0366	972	675	71.5
1x630	6/10	29.9	37.5	45	49	6862	500	0.0283	1078	734	90.1
1x35	8.7/15	7.0	17.5	24	27	847	1000	0.5240	194	165	5.0
1x50	8.7/15	8.2	18.0	25	28	977	1000	0.3870	238	196	7.2
1x70	8.7/15	9.8	19.5	27	30	1209	1000	0.2680	296	239	10.0
1x95	8.7/15	11.3	21.5	28	31	1487	1000	0.1930	361	285	13.6
1x120	8.7/15	12.8	23.0	30	33	1757	1000	0.1530	417	323	17.2
1x150	8.7/15	14.2	24.0	31	34	2041	1000	0.1240	473	361	21.5
1x185	8.7/15	15.7	25.5	33	36	2418	1000	0.0991	543	406	26.5
1x240	8.7/15	18.2	28.0	35	39	3000	1000	0.0754	641	469	34.3
1x300	8.7/15	20.4	30.5	37	41	3612	1000	0.0601	718	525	42.9
1x400	8.7/15	22.8	33.0	40	43	4455	1000	0.0470	845	590	57.2
1x500	8.7/15	26.1	36.0	43	47	5511	500	0.0366	972	675	71.5
1x630	8.7/15	29.9	40.0	47	52	7048	500	0.0283	1078	734	90.1

Dimension and Electrical Data (cont.)

Cross Section	Tension U ₀ /U	Conductor Diameter	Insulation Diameter	Non Metallic Armour Diameter	Outer Sheath Diameter	Cable Weight	Packaging	Max DC Resistance at 20°C	Current Rating in air at 30°C	Current Rating in ground at 20°C	Short Circuit Current for 1s
mm ²	kV	mm	mm	mm	mm	kg/km	m	Ω/km	A	A	kA
1x35	12/20	7.0	19.0	26	29	929	1000	0.5240	194	165	5.0
1x50	12/20	8.2	20.0	27	30	1062	1000	0.3870	238	196	7.2
1x70	12/20	9.8	21.5	29	32	1313	1000	0.2680	296	239	10.0
1x95	12/20	11.3	23.0	30	33	1597	1000	0.1930	361	285	13.6
1x120	12/20	12.8	24.5	32	35	1898	1000	0.1530	417	323	17.2
1x150	12/20	14.2	26.0	33	37	2189	1000	0.1240	473	361	21.5
1x185	12/20	15.7	27.5	35	38	2573	1000	0.0991	543	406	26.5
1x240	12/20	18.2	30.0	37	41	3148	1000	0.0754	641	469	34.3
1x300	12/20	20.4	32.5	39	43	3777	1000	0.0601	718	525	42.9
1x400	12/20	22.8	34.5	42	46	4642	1000	0.0470	845	590	57.2
1x500	12/20	26.1	38.0	45	49	5714	500	0.0366	972	675	71.5
1x630	12/20	29.9	42.0	49	54	7246	500	0.0283	1078	734	90.1
1x50	18/30	8.2	25.0	32	35	1331	1000	0.3870	238	196	7.2
1x70	18/30	9.8	26.5	34	37	1580	1000	0.2680	296	239	10.0
1x95	18/30	11.3	28.0	35	39	1894	1000	0.1930	361	285	13.6
1x120	18/30	12.8	29.5	37	40	2164	1000	0.1530	417	323	17.2
1x150	18/30	14.2	31.0	38	42	2473	1000	0.1240	473	361	21.5
1x185	18/30	15.7	32.5	39	43	2849	1000	0.0991	543	406	26.5
1x240	18/30	18.2	35.0	42	46	3494	1000	0.0754	641	469	34.3
1x300	18/30	20.4	37.0	44	48	4155	1000	0.0601	718	525	42.9
1x400	18/30	22.8	39.5	47	51	5002	1000	0.0470	845	590	57.2
1x500	18/30	26.1	43.0	50	54	6099	500	0.0366	972	675	71.5
1x630	18/30	29.9	46.5	54	59	7665	500	0.0283	1078	734	90.1

AIR BAG™ Polymeric Armored Cable

3.6/6(7.2) - 18/30(36) kV

3C CU/XLPE/CTS/PVC/AB/PVC



CONSTRUCTION

Conductor	: Plain annealed copper wire according to IEC 60228 - Class 2 for Stranded Compacted Conductors
Conductor Screen	: Extruded Semi Conductive Compound
Insulation	: XLPE Compound
Insulation Screen	: Extruded Semi Conductive Compound
Metallic Screen	: Plain Annealed Copper Tapes
Filler	: Non Hygroscopic Filler
Non Metallic Armour	: AB HPA High grade Polymeric Armor
Sheath	: PVC ST 2 Compound

APPLICABLE STANDARDS

SNI IEC 60502-2, IEC 60502-2
IEC 60228
IEC 60332-1
IEC 60332-3-24

Special features on request:
EPR Insulation
Flame Retardant Cat. A, B, C
Flame Retardant Non Category
Anti-termites
Anti-rodent

Design and Test Guidelines
Conductor
Flame Retardant
Flame Retardant Cat. C

Oil Resistance
UV Resistance
Low Smoke Zero Halogen
PE ST7

IDENTIFICATIONS

Core: Brown, Black, Grey

Others colours available upon request



IEC 60332-1
IEC 60332-3-24



Standard



Excellent



0°C



12 D



Normal
Operation
Temperature



Short
Circuit
Temperature

Dimension and Electrical Data

Cross Section	Tension U ₀ /U	Conductor Diameter	Insulation Diameter	Non Metallic Armour Diameter	Outer Sheath Diameter	Cable Weight	Packaging	Max DC Resistance at 20°C	Current Rating in air at 30°C	Current Rating in ground at 20°C	Short Circuit Current for 1s
mm ²	kV	mm	mm	mm	mm	kg/km	m	Ω/km	A	A	kA
3x35	3.6/6	7.0	14.5	42	46	2849	1000	0.5240	170	153	5.0
3x50	3.6/6	8.2	15.5	44	48	3293	1000	0.3870	204	181	7.2
3x70	3.6/6	9.8	17.0	48	54	4154	1000	0.2680	253	221	10.0
3x95	3.6/6	11.3	18.5	51	58	5089	500	0.1930	304	262	13.6
3x120	3.6/6	12.8	20.0	54	61	6016	500	0.1530	351	298	17.2
3x150	3.6/6	14.2	21.5	60	65	7410	500	0.1240	398	334	21.5
3x185	3.6/6	15.7	23.0	63	68	8700	500	0.0991	455	377	26.5
3x240	3.6/6	18.2	25.0	65	72	9979	250	0.0754	531	434	34.3
3x300	3.6/6	20.4	28.0	73	79	13131	250	0.0601	606	489	42.9
3x35	6/10	7.0	15.5	45	49	3272	1000	0.5240	170	153	5.0
3x50	6/10	8.2	16.0	46	51	3609	1000	0.3870	204	181	7.2
3x70	6/10	9.8	17.5	50	54	4448	1000	0.2680	253	221	10.0
3x95	6/10	11.3	19.0	53	58	5462	500	0.1930	304	262	13.6
3x120	6/10	12.8	20.5	58	63	6548	500	0.1530	351	298	17.2
3x150	6/10	14.2	22.0	61	66	7589	500	0.1240	398	334	21.5
3x185	6/10	15.7	23.5	65	70	8889	500	0.0991	455	377	26.5
3x240	6/10	18.2	26.0	70	75	10979	250	0.0754	531	434	34.3
3x300	6/10	20.4	28.0	75	81	13214	250	0.0601	606	489	42.9
3x35	8.7/15	7.0	17.5	49	53	3604	1000	0.5240	170	153	5.0
3x50	8.7/15	8.2	18.0	51	56	4109	1000	0.3870	204	181	7.2
3x70	8.7/15	9.8	19.5	54	59	5008	1000	0.2680	253	221	10.0
3x95	8.7/15	11.3	21.5	60	65	6202	500	0.1930	304	262	13.6
3x120	8.7/15	12.8	23.0	63	68	7188	500	0.1530	351	298	17.2
3x150	8.7/15	14.2	24.0	66	71	8260	500	0.1240	398	334	21.5
3x185	8.7/15	15.7	25.5	69	75	9594	500	0.0991	455	377	26.5
3x240	8.7/15	18.2	28.0	75	80	11741	500	0.0754	531	434	34.3
3x300	8.7/15	20.4	30.5	79	85	13967	500	0.0601	606	489	42.9

Dimension and Electrical Data

Cross Section	Tension U ₀ /U	Conductor Diameter	Insulation Diameter	Non Metallic Armour Diameter	Outer Sheath Diameter	Cable Weight	Packaging	Max DC Resistance at 20°C	Current Rating in air at 30°C	Current Rating in ground at 20°C	Short Circuit Current for 1s
mm ²	kV	mm	mm	mm	mm	kg/km	m	Ω/km	A	A	kA
3x35	12/20	7.0	19.0	53	58	4082	1000	0.5240	170	153	5.0
3x50	12/20	8.2	20.5	55	60	4628	500	0.3870	204	181	7.2
3x70	12/20	9.8	21.5	60	65	5654	500	0.2680	253	221	10.0
3x95	12/20	11.3	23.0	63	69	6735	500	0.1930	304	262	13.6
3x120	12/20	12.8	24.5	67	72	7774	250	0.1530	351	298	17.2
3x150	12/20	14.2	26.0	69	75	8872	250	0.1240	398	334	21.5
3x185	12/20	15.7	27.5	73	79	10235	250	0.0991	455	377	26.5
3x240	12/20	18.2	30.0	79	85	12423	250	0.0754	531	434	34.3
3x300	12/20	20.4	32.5	84	90	14752	250	0.0601	606	489	42.9
3x50	18/30	8.2	25.0	68	73	6221	500	0.3870	204	181	7.2
3x70	18/30	9.8	27.0	71	77	7440	500	0.2680	253	221	10.0
3x95	18/30	11.3	28.0	73	79	8131	500	0.1930	304	262	13.6
3x120	18/30	12.8	29.5	76	82	9210	500	0.1530	351	298	17.2
3x150	18/30	14.2	31.0	79	86	10327	250	0.1240	398	334	21.5
3x185	18/30	15.7	32.5	82	90	11088	250	0.0991	455	377	26.5
3x240	18/30	18.2	35.0	87	95	13270	250	0.0754	531	434	34.3
3x300	18/30	20.4	37.0	94	101	16855	250	0.0601	606	489	42.9

AIR BAG™ Polymeric Armored Cable

3.6/6(7.2) - 18/30(36) kV

1C AL/XLPE/CTS/AB/PVC



CONSTRUCTION

Conductor	: Stranded Aluminium according to IEC 60228 - Class 2 for Stranded Compacted Conductors
Conductor Screen	: Extruded Semi Conductive Compound
Insulation	: XLPE Compound
Insulation Screen	: Extruded Semi Conductive Compound
Metallic Screen	: Plain Annealed Copper Tapes
Non Metallic Armour	: AB HPA High grade Polymeric Armor
Sheath	: PVC Compound ST 2

APPLICABLE STANDARDS

SNI IEC 60502-2, IEC 60502-2
IEC 60228
IEC 60332-1
IEC 60332-3-24

Special features on request:
EPR Insulation
Flame Retardant Cat. A, B, C
Flame Retardant Non Category
Anti-termites
Anti-rodent

Design and Test Guidelines
Conductor
Flame Retardant
Flame Retardant Cat. C

Oil Resistance
UV Resistance
Low Smoke Zero Halogen
PE ST7

IDENTIFICATIONS

Core Not Applicable



IEC 60332-1
IEC 60332-3-24



Standard



Excellent



0°C



12 D



Normal
Operation
Temperature



Short
Circuit
Temperature

Dimension and Electrical Data

Cross Section	Tension U ₀ /U	Conductor Diameter	Insulation Diameter	Non Metallic Armour Diameter	Outer Sheath Diameter	Cable Weight	Packaging	Max DC Resistance at 20°C	Current Rating in air at 30°C	Current Rating in ground at 20°C	Short Circuit Current for 1s
mm ²	kV	mm	mm	mm	mm	kg/km	m	Ω/km	A	A	kA
1x50	3.6/6	8.1	15.5	23	26	596	1000	0.6410	184	152	4.7
1x70	3.6/6	9.7	17.0	24	27	684	1000	0.4430	230	186	6.6
1x95	3.6/6	11.3	18.5	25	28	785	1000	0.3200	280	221	9.0
1x120	3.6/6	12.8	20.0	27	30	891	1000	0.2530	324	252	11.3
1x150	3.6/6	14.0	21.0	28	31	984	1000	0.2060	368	281	14.2
1x185	3.6/6	15.7	22.5	30	33	1139	1000	0.1640	424	317	17.5
1x240	3.6/6	18.0	25.0	32	35	1356	1000	0.1250	502	367	22.7
1x300	3.6/6	20.2	27.5	34	38	1610	1000	0.1000	577	414	28.3
1x400	3.6/6	22.7	30.0	37	40	1905	1000	0.0778	673	470	37.8
1x500	3.6/6	26.1	33.5	41	44	2323	1000	0.0605	801	540	47.2
1x630	3.6/6	30.0	37.5	45	49	2937	1000	0.0469	915	600	59.5
1x50	6/10	8.1	16.0	23	26	611	1000	0.6410	184	152	4.7
1x70	6/10	9.7	17.5	25	28	700	1000	0.4430	230	186	6.6
1x95	6/10	11.3	19.0	26	29	820	1000	0.32000	280	221	9.0
1x120	6/10	12.8	20.5	28	31	927	1000	0.2530	324	252	11.3
1x150	6/10	14.0	22.0	29	32	1036	1000	0.2060	368	281	14.2
1x185	6/10	15.7	23.5	31	34	1179	1000	0.1640	424	317	17.5
1x240	6/10	18.0	26.0	33	36	1416	1000	0.1250	502	367	22.7
1x300	6/10	20.2	28.0	35	39	1673	1000	0.1000	577	414	28.3
1x400	6/10	22.7	30.5	38	41	1962	1000	0.0778	673	470	37.8
1x500	6/10	26.1	34.0	41	45	2371	1000	0.0605	801	540	47.2
1x630	6/10	30.0	38.0	45	49	2990	500	0.0469	915	600	59.5
1x50	8.7/15	8.1	18.0	25	28	691	1000	0.6410	184	152	4.7
1x70	8.7/15	9.7	19.5	27	30	793	1000	0.4430	230	186	6.6
1x95	8.7/15	11.3	21.5	28	31	917	1000	0.3200	280	221	9.0
1x120	8.7/15	12.8	22.5	30	33	1044	1000	0.2530	324	252	11.3
1x150	8.7/15	14.0	24.0	31	34	1143	1000	0.2060	368	281	14.2
1x185	8.7/15	15.7	25.5	33	36	1307	1000	0.1640	424	317	17.5
1x240	8.7/15	18.0	28.0	35	39	1553	1000	0.1250	502	367	22.7
1x300	8.7/15	20.2	30.0	37	41	1801	1000	0.1000	577	414	28.3
1x400	8.7/15	22.7	32.5	40	43	2098	1000	0.0778	673	470	37.8
1x500	8.7/15	26.1	36.0	43	47	2518	1000	0.0605	801	540	47.2
1x630	8.7/15	30.0	40.0	47	52	3176	500	0.0469	915	600	59.5

Dimension and Electrical Data

Cross Section	Tension U ₀ /U	Conductor Diameter	Insulation Diameter	Non Metallic Armour Diameter	Outer Sheath Diameter	Cable Weight	Packaging	Max DC Resistance at 20°C	Current Rating in air at 30°C	Current Rating in ground at 20°C	Short Circuit Current for 1s
mm ²	kV	mm	mm	mm	mm	kg/km	m	Ω/km	A	A	kA
1x50	12/20	8.1	20.0	27	30	776	1000	0.6410	184	152	4.7
1x70	12/20	9.7	21.5	29	32	896	1000	0.4430	230	186	6.6
1x95	12/20	11.3	23.0	30	33	1026	1000	0.3200	280	221	9.0
1x120	12/20	12.8	24.5	32	35	1159	1000	0.2530	324	252	11.3
1x150	12/20	14.0	26.0	33	36	1262	1000	0.2060	368	281	14.2
1x185	12/20	15.7	27.5	35	38	1433	1000	0.1640	424	317	17.5
1x240	12/20	18.0	30.0	37	41	1669	1000	0.1250	502	367	22.7
1x300	12/20	20.2	32.0	39	43	1933	1000	0.1000	577	414	28.3
1x400	12/20	22.7	34.5	42	46	2248	1000	0.0778	673	470	37.8
1x500	12/20	26.1	38.0	45	49	2680	1000	0.0605	801	540	47.2
1x630	12/20	30.0	42.0	49	54	3330	500	0.0469	915	600	59.5
1x50	18/30	8.1	25.0	32	35	1044	1000	0.6410	184	152	4.7
1x70	18/30	9.7	26.5	33	37	1163	1000	0.4430	230	186	6.6
1x95	18/30	11.3	28.0	35	39	1323	1000	0.32000	280	221	9.0
1x120	18/30	12.8	29.5	37	40	1451	1000	0.2530	324	252	11.3
1x150	18/30	14.0	31.0	38	41	1573	1000	0.2060	368	281	14.2
1x185	18/30	15.7	32.5	39	43	1739	1000	0.1640	424	317	17.5
1x240	18/30	18.0	35.0	42	46	2014	1000	0.1250	502	367	22.7
1x300	18/30	20.2	37.0	44	48	2307	1000	0.1000	577	414	28.3
1x400	18/30	22.7	39.5	46	51	2644	1000	0.0778	673	470	37.8
1x500	18/30	26.1	43.0	50	54	3106	1000	0.0605	801	540	47.2
1x630	18/30	30.0	47.0	54	59	3774	500	0.0469	915	600	59.5

AIR BAG™ Polymeric Armored Cable

3.6/6(7.2) - 18/30(36) kV

3C AL/XLPE/CTS/PVC/AB/PVC



CONSTRUCTION

Conductor	: Stranded Aluminium according to IEC 60228 - Class 2 for Stranded Compacted Conductors
Conductor Screen	: Extruded Semi Conductive Compound
Insulation	: XLPE Compound
Insulation Screen	: Extruded Semi Conductive Compound
Metallic Screen	: Plain Annealed Copper Tapes
Filler	: Non Hygroscopic filler
Non Metallic Armour	: AB HPA High grade Polymeric Armor
Sheath	: PVC ST2 Compound

APPLICABLE STANDARDS

SNI IEC 60502-2, IEC 60502-2
IEC 60228
IEC 60332-1
IEC 60332-3-24

Special features on request:
EPR Insulation
Flame Retardant Cat. A, B, C
Flame Retardant Non Category
Anti-termites
Anti-rodent

Design and Test Guidelines
Conductor
Flame Retardant
Flame Retardant Cat. C

Oil Resistance
UV Resistance
Low Smoke Zero Halogen
PE ST7

IDENTIFICATIONS

Core Brown, Black, Grey

Others colours available upon request



IEC 60332-1
IEC 60332-3-24



Standard



Excellent



0°C



12 D



Normal
Operation
Temperature



Short
Circuit
Temperature

Dimension and Electrical Data

Cross Section	Tension U ₀ /U	Conductor Diameter	Insulation Diameter	Non Metallic Armour Diameter	Outer Sheath Diameter	Cable Weight	Packaging	Max DC Resistance at 20°C	Current Rating in air at 30°C	Current Rating in ground at 20°C	Short Circuit Current for 1s
mm ²	kV	mm	mm	mm	mm	kg/km	m	Ω/km	A	A	kA
3x50	3.6/6	8.1	15.5	45	49	2616	1000	0.6410	158	140	4.7
3x70	3.6/6	9.7	17.0	48	52	3050	1000	0.4430	196	171	6.6
3x95	3.6/6	11.3	18.5	51	55	3529	1000	0.3200	236	203	9.0
3x120	3.6/6	12.8	20.0	54	59	4029	1000	0.2530	273	232	11.3
3x150	3.6/6	14	21.0	59	63	4638	1000	0.2060	309	260	14.2
3x185	3.6/6	15.7	22.5	62	67	5290	1000	0.1640	355	294	17.5
3x240	3.6/6	18	25.0	68	73	6333	500	0.1250	415	340	22.7
3x300	3.6/6	20.2	27.0	72	78	7443	500	0.1000	475	384	28.3
3x50	6/10	8.1	16.0	46	50	2744	1000	0.6410	158	140	4.7
3x70	6/10	9.7	17.5	49	54	3190	1000	0.4430	196	171	6.6
3x95	6/10	11.3	19.0	53	57	3745	1000	0.3200	236	203	9.0
3x120	6/10	12.8	20.5	58	63	4398	1000	0.2530	273	232	11.3
3x150	6/10	14	22.0	61	65	4883	1000	0.2060	309	260	14.2
3x185	6/10	15.7	23.5	64	69	5550	500	0.1640	355	294	17.5
3x240	6/10	18	26.0	69	75	6613	500	0.1250	415	340	22.7
3x300	6/10	20.2	28.0	74	80	7720	500	0.1000	475	384	28.3
3x50	8.7/15	8.1	18.0	50	55	3243	1000	0.6410	158	140	4.7
3x70	8.7/15	9.7	19.5	54	59	3749	1000	0.4430	196	171	6.6
3x95	8.7/15	11.3	21.5	59	64	4485	1000	0.3200	236	203	9.0
3x120	8.7/15	12.8	22.5	62	68	5038	1000	0.2530	273	232	11.3
3x150	8.7/15	14	24.0	65	70	5551	500	0.2060	309	260	14.2
3x185	8.7/15	15.7	25.5	69	74	6256	500	0.1640	355	294	17.5
3x240	8.7/15	18	28.0	74	80	7373	500	0.1250	415	340	22.7
3x300	8.7/15	20.2	30.0	79	85	8494	500	0.1000	475	384	28.3

Dimension and Electrical Data

Cross Section	Tension U ₀ /U	Conductor Diameter	Insulation Diameter	Non Metallic Armour Diameter	Outer Sheath Diameter	Cable Weight	Packaging	Max DC Resistance at 20°C	Current Rating in air at 30°C	Current Rating in ground at 20°C	Short Circuit Current for 1s
mm ²	kV	mm	mm	mm	mm	kg/km	m	Ω/km	A	A	kA
3x50	8.1	12/20	20.0	55	59	3738	1000	0.6410	158	140	4.7
3x70	9.7	12/20	21.5	60	65	4419	1000	0.4430	196	171	6.6
3x95	11.3	12/20	23.0	64	69	5051	1000	0.3200	236	203	9.0
3x120	12.8	12/20	24.5	67	72	5632	500	0.2530	273	232	11.3
3x150	14	12/20	26.0	69	75	6170	500	0.2060	309	260	14.2
3x185	15.7	12/20	27.5	73	79	6945	500	0.1640	355	294	17.5
3x240	18	12/20	30.0	78	84	8052	500	0.1250	415	340	22.7
3x300	20.2	12/20	32.0	83	89	9277	500	0.1000	475	384	28.3
3x50	8.1	18/30	25.0	67	73	5333	500	0.6410	158	140	4.7
3x70	9.7	18/30	26.5	71	76	5977	500	0.4430	196	171	6.6
3x95	11.3	18/30	28.0	74	80	6691	500	0.320	236	203	9.0
3x120	12.8	18/30	29.5	77	83	7325	500	0.2530	273	232	11.3
3x150	14	18/30	30.5	80	86	7884	250	0.2060	309	260	14.2
3x185	15.7	18/30	32.5	83	90	8748	500	0.1640	355	294	17.5
3x240	18	18/30	35.0	89	95	10033	250	0.1250	415	340	22.7
3x300	20.2	18/30	37.0	93	100	11371	250	0.1000	475	384	28.3

Rating Factors for XLPE/EPR Insulated MV Cables

Installation Condition Data

Maximum Conductor Temperature	XLPE	°C	90
	EPR	°C	90
Base Temperature	In Air	°C	30
	In Ground	°C	20
Soil Thermal Resistivity		Km/W	1.5
Depth of laying		m	0.8

Cable Arrangement

d = Cable Overall Diameter

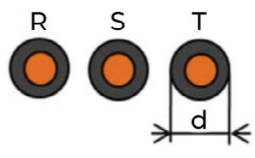
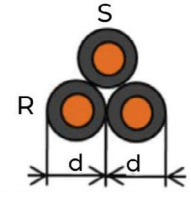
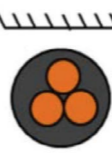
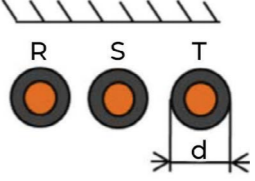
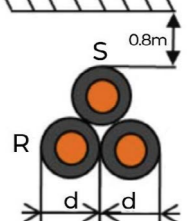
Method of Laying	Ambient Temperature	Cable Lay-out		
		1 multicore Cable	3 Single Core Cabled in 3 phase System	
			Flat Formation	Trefoil Formation
Installed in free air	30°C			
Installed direct in ground	30°C			

Rating Factor

The following factors are used for calculation based on the current rating stated on the catalogue for XLPE and EPR Insulation with different Laying condition

A. CABLES LAID DIRECT IN GROUND

A.1 Rating Factor for Variation of Ground Temperature

Ground Temperature (°C)		10	15	20	25	30	35	40	45	50
Rating Factor	XLPE	1.07	1.04	1.00	0.96	0.93	0.89	0.85	0.80	0.76
	EPR	1.07	1.04	1.00	0.96	0.93	0.89	0.85	0.80	0.76

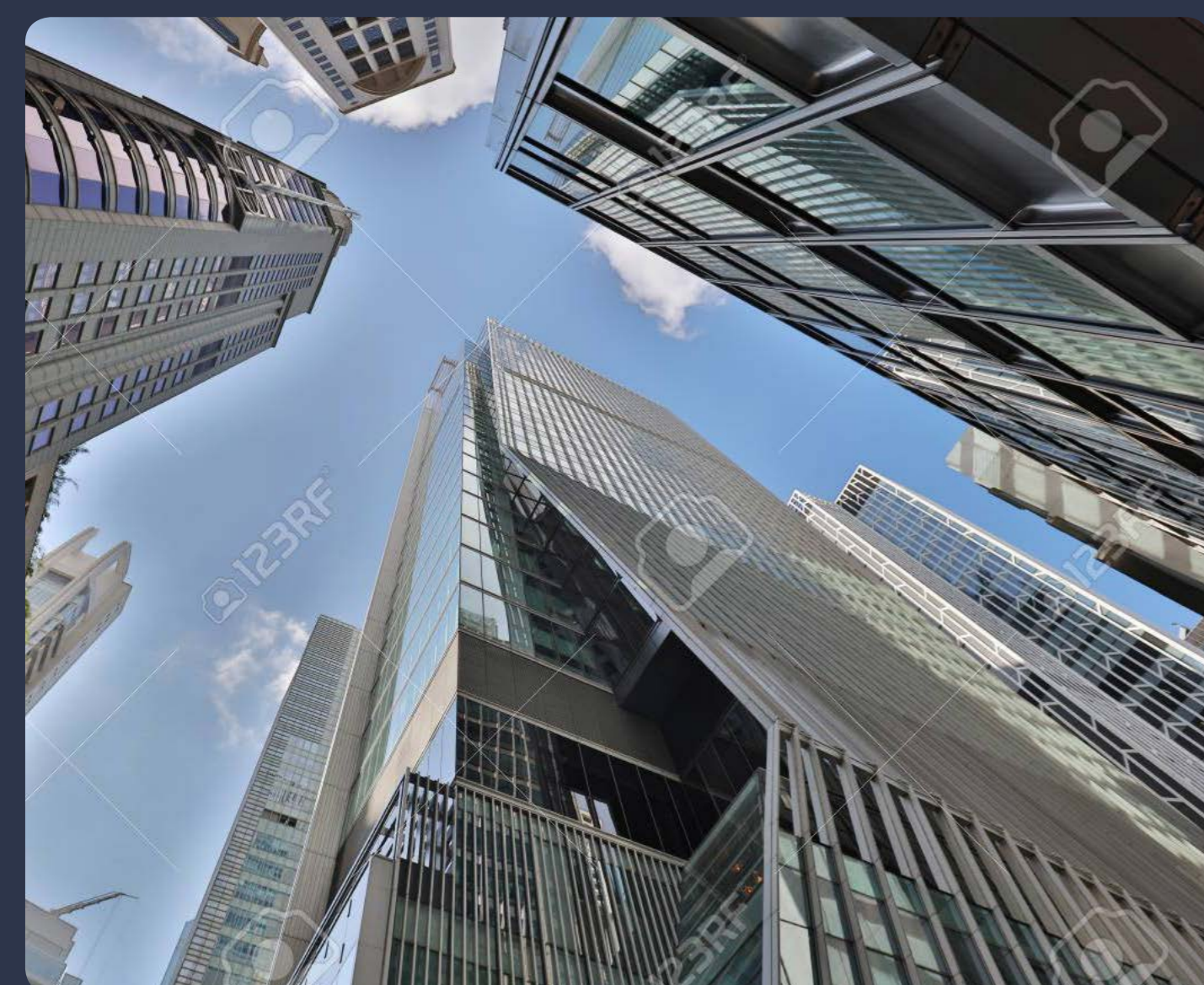

A.2 Rating Factor for Variation of Depth of Laying in Ground

Depth of Laying (m)	Single Core Cables		Three Cores Cables
	Nominal Conductor size (mm ²)		
	< 185 mm ²	> 185 mm ²	
0.5	1.04	1.06	1.04
0.6	1.02	1.04	1.03
1.0	0.98	0.97	0.98
1.25	0.96	0.96	0.96
1.5	0.95	0.93	0.95
1.75	0.94	0.91	0.94
2.0	0.93	0.90	0.93
2.5	0.91	0.88	0.91
3.0	0.9	0.86	0.90

A.3 Rating Factor for Thermal Resistivity of Soil for Direct Burried Single Core

Nominal Area of Conductor (mm ²)	Value of Soil Thermal Resistivity (K.m/W)							
	0.7	0.8	0.9	1.0	1.5	2.0	2.5	3.0
16	1.29	1.24	1.14	1.15	1.0	0.89	0.82	0.75
25	1.30	1.25	1.14	1.16	1.0	0.89	0.81	0.75
35	1.30	1.25	1.15	1.16	1.0	0.89	0.81	0.75
50	1.32	1.26	1.15	1.16	1.0	0.89	0.81	0.74
70	1.33	1.27	1.15	1.17	1.0	0.89	0.81	0.74
95	1.34	1.28	1.16	1.18	1.0	0.89	0.80	0.74
120	1.34	1.28	1.16	1.18	1.0	0.88	0.80	0.74
150	1.35	1.28	1.16	1.18	1.0	0.88	0.80	0.74
185	1.35	1.29	1.17	1.18	1.0	0.88	0.80	0.74
240	1.36	1.29	1.17	1.18	1.0	0.88	0.80	0.73
300	1.36	1.30	1.17	1.19	1.0	0.88	0.80	0.73
400	1.37	1.30	1.17	1.19	1.0	0.88	0.79	0.73

A.4 Rating Factor for Thermal Resistivity of Soil for Direct Burried Three Cores

Nominal Area of Conductor (mm ²)	Value of Soil Thermal Resistivity (K.m/W)							
	0.7	0.8	0.9	1.0	1.5	2.0	2.5	3.0
16	1.23	1.10	1.16	1.13	1.0	0.91	0.84	0.78
25	1.24	1.20	1.16	1.13	1.0	0.91	0.84	0.78
35	1.25	1.21	1.17	1.13	1.0	0.91	0.83	0.78
50	1.25	1.21	1.17	1.14	1.0	0.91	0.83	0.77
70	1.26	1.21	1.18	1.14	1.0	0.90	0.83	0.77
95	1.26	1.22	1.18	1.14	1.0	0.90	0.83	0.77
120	1.26	1.22	1.18	1.14	1.0	0.90	0.83	0.77
150	1.27	1.22	1.18	1.15	1.0	0.90	0.83	0.77
185	1.28	1.23	1.18	1.15	1.0	0.90	0.83	0.77
240	1.28	1.23	1.19	1.15	1.0	0.90	0.83	0.77
300	1.28	1.23	1.19	1.15	1.0	0.90	0.82	0.77
400	1.28	1.23	1.19	1.15	1.0	0.90	0.82	0.76

A.5 Rating Factor For Grouping Of Three Core Cables in Horizontal Formation Laid Direct In The Ground

Number of Cables in Group	Spacing Between Cables Centre (mm)				
	Touching	200	400	600	800
2	0.80	0.86	0.90	0.92	0.94
3	0.69	0.77	0.82	0.86	0.89
4	0.62	0.72	0.79	0.83	0.87
5	0.57	0.68	0.75	0.81	0.85
6	0.64	0.65	0.74	0.80	0.84
7	0.51	0.63	0.72	0.78	0.83
8	0.47	0.61	0.71	0.78	-
9	0.46	0.60	0.70	0.77	-
10	0.46	0.58	0.69	-	-
11	0.45	0.57	0.69	-	-
12	0.43	0.58	0.68	-	-

A.6 Rating Factor for Grouping of Three Phase Circuit of Single Core Cables Laid Direct in the Ground

Number of Cables in Group	Spacing Between Cables Centre (mm)				
	Touching	200	400	600	800
2	0.73	0.83	0.88	0.90	0.92
3	0.60	0.73	0.79	0.83	0.86
4	0.54	0.68	0.75	0.80	0.84
5	0.46	0.63	0.72	0.78	0.82
6	0.48	0.61	0.70	0.76	0.81
7	0.43	0.58	0.68	0.75	-
8	0.41	0.57	0.67	0.74	-
9	0.36	0.55	0.66	0.73	-
10	0.37	0.54	0.65	-	-
11	0.36	0.53	0.64	-	-
12	0.35	0.52	0.64	-	-

B.2 Rating Factor for Thermal Resistivity of Soil for Burried Duct Single Core

Nominal Area of Conductor (mm ²)	Value of Soil Thermal Resistivity (K.m/W)							
	0.7	0.8	0.9	1.0	1.5	2.0	2.5	3.0
16	1.20	1.17	1.14	1.11	1.0	0.92	0.85	0.79
25	1.21	1.17	1.14	1.12	1.0	0.91	0.85	0.79
35	1.21	1.18	1.15	1.12	1.0	0.91	0.84	0.79
50	1.21	1.18	1.15	1.12	1.0	0.91	0.84	0.79
70	1.22	1.19	1.15	1.12	1.0	0.91	0.84	0.78
95	1.22	1.19	1.16	1.13	1.0	0.91	0.84	0.78
120	1.22	1.20	1.16	1.13	1.0	0.91	0.84	0.78
150	1.24	1.20	1.16	1.13	1.0	0.91	0.83	0.78
185	1.24	1.20	1.17	1.13	1.0	0.91	0.83	0.78
240	1.25	1.21	1.17	1.14	1.0	0.90	0.83	0.77
300	1.25	1.21	1.17	1.14	1.0	0.90	0.83	0.77
400	1.25	1.21	1.17	1.14	1.0	0.90	0.83	0.77

B. CABLES LAID DIRECT IN DUCT

B.1 Rating Factor for Variation of Depth of Laying in Duct

Depth of Laying (m)	Single Core Cables		Three Cores Cables
	Nominal Conductor size (mm ²)		
	< 185 mm ²	> 185 mm ²	
0.5	1.04	1.05	1.03
0.6	1.02	1.03	1.02
1.0	0.98	0.97	0.99
12.5	0.96	0.95	0.97
1.5	0.95	0.93	0.96
1.75	0.94	0.92	0.95
2.0	0.93	0.91	0.94
2.5	0.91	0.89	0.93
3.0	0.90	0.88	0.92

B.3 Rating Factor for Thermal Resistivity of Soil for Three Core in Ducts

Nominal Area of Conductor (mm ²)	Value of Soil Thermal Resistivity (K.m/W)							
	0.7	0.8	0.9	1.0	1.5	2.0	2.5	3.0
16	1.12	1.11	1.09	1.09	1.0	0.94	0.89	0.84
25	1.14	1.12	1.10	1.08	1.0	0.94	0.89	0.84
35	1.14	1.12	1.10	1.08	1.0	0.94	0.88	0.84
50	1.14	1.12	1.10	1.08	1.0	0.94	0.88	0.84
70	1.15	1.13	1.11	1.09	1.0	0.94	0.88	0.83
95	1.15	1.13	1.11	1.09	1.0	0.94	0.88	0.83
120	1.15	1.13	1.11	1.09	1.0	0.93	0.88	0.83
150	1.16	1.13	1.11	1.09	1.0	0.93	0.88	0.83
185	1.16	1.14	1.11	1.09	1.0	0.93	0.87	0.83
240	1.16	1.14	1.12	1.10	1.0	0.93	0.87	0.82
300	1.17	1.14	1.12	1.10	1.0	0.93	0.87	0.82
400	1.17	1.14	1.12	1.10	1.0	0.92	0.86	0.81

B.4 Rating Factor for Grouping of Three core cables in single way duct in horizontal formation

Number of Cables in Group	Spacing Between Cables Centre (mm)				
	Touching	200	400	600	800
2	0.85	0.88	0.92	0.94	0.95
3	0.75	0.80	0.85	0.88	0.91
4	0.69	0.75	0.82	0.86	0.89
5	0.65	0.72	0.79	0.84	0.87
6	0.62	0.69	0.77	0.83	0.87
7	0.59	0.67	0.76	0.82	0.86
8	0.57	0.65	0.75	0.81	-
9	0.55	0.64	0.74	0.80	-
10	0.54	0.63	0.73	-	-
11	0.52	0.62	0.73	-	-
12	0.51	0.61	0.72	-	-

B.5 Rating Factor for Grouping of Three Phase circuits of Single core cables in single way duct



Number of Cables in Group	Spacing Between Cables Centre (mm)				
	Touching	200	400	600	800
2	0.78	0.85	0.89	0.91	0.93
3	0.68	0.75	0.81	0.85	0.88
4	0.59	0.70	0.77	0.82	0.88
5	0.55	0.66	0.74	0.80	0.84
6	0.51	0.64	0.72	0.78	0.83
7	0.48	0.61	0.71	0.77	0.82
8	0.46	0.60	0.70	0.76	-
9	0.44	0.58	0.69	0.76	-
10	0.43	0.57	0.68	-	-
11	0.42	0.56	0.67	-	-
12	0.40	0.55	0.67	-	-

C. CABLES INSTALLED IN FREE AIR

C.1 Rating Factor for Variation in Air Temperature

Air Temperature (°C)		20	25	30	35	40	45	50	55	60
		Rating Factor	XLPE	1.08	1.04	1.00	0.96	0.91	0.87	0.82
	EPR	1.08	1.04	1.00	0.96	0.91	0.87	0.82	0.78	0.71

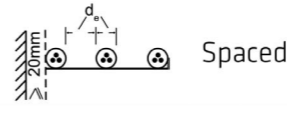
C.2 Rating Factor for Group of More Than One Multicore Cable in Air

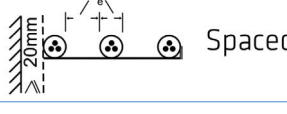
Method of Installation	Number of Trays	Number of Cables						
		1	2	3	4	5	6	
Cable on Perforated Trays	 Touching	1	1.00	0.88	0.82	0.79	0.76	0.73
		2	1.00	0.87	0.80	0.77	0.73	0.68
	3	1.00	0.86	0.79	0.76	0.71	0.66	
Cable on Vertical Perforated Trays	 Spaced	1	1.00	1.00	0.98	0.95	0.91	-
		2	1.00	0.99	0.96	0.92	0.67	-
	3	1.00	0.98	0.95	0.91	0.85	-	
Cables on Ladder Support, Cleats, etc	 Touching	1	1.00	0.87	0.82	0.80	0.79	0.78
		2	1.00	0.86	0.80	0.78	0.76	0.73
	3	1.00	0.85	0.79	0.76	0.73	0.70	
	 Spaced	1	1.00	1.00	1.00	1.00	1.00	-
		2	1.00	0.99	0.98	0.97	0.96	-
	3	1.00	0.98	0.97	0.96	0.93	-	

- Note 1:** Values given are averages for the cables types and rang of conductor sizes considered. The spread of values is generally less than 5%.
- Note 2:** Factors apply to single layer of cable shown above and do not apply when cables are installed in more than one layer touching each other. Values for such installations may be significantly lower and should be determined by an appropriate method.
- Note 3:** Values are given for vertical spacing between trays of 300 mm and at least 20 mm between trays and wall. For closer spacing, the factors should be reduced.
- Note 4:** Values are given to horizontal spacing between trays of 225 mm with trays mounted back to back. For closer spacing the factors should be reduced.

C.3 Rating Factor for Group of More Than One CIRCUIT OF Single Core Cable

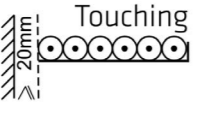
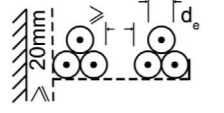
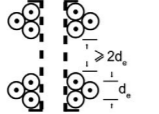
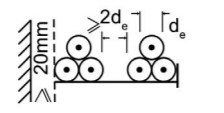
Method of Installation	Number of Trays	Number of Three Phase Circuit (Note 5)			Use as A Multiplier to Rating for
		1	2	3	
Perforated Trays (Note 3) 	1	0.98	0.91	0.87	Three cables in horizontal formation
	2	0.96	0.87	0.81	
	3	0.95	0.85	0.78	
Perforated Trays (Note 3) 	1	1.00	0.97	0.96	Three cables in horizontal formation
	2	0.98	0.93	0.89	
	3	0.97	0.90	0.86	
Perforated Trays (Note 3) 	1	1.00	0.98	0.96	Three cables in horizontal formation
	2	0.97	0.93	0.89	
	3	0.96	0.92	0.86	
Perforated Trays (Note 3) 	1	1.00	0.91	0.89	Three cables in trefoil formation
	2	1.00	0.90	0.86	
Perforated Trays (Note 3) 	1	1.00	1.00	0.100	Three cables in horizontal formation
	2	0.97	0.95	0.93	
	3	0.96	0.94	0.90	

Note 1: Values given are averages for the cables types and rang of conductor sizes considered. The spread of values is generally less than 5%.

Note 2: Factors are given for single layers of cable (of trefoil groups) as shown in the table and do not apply when cables are installed in more than one layer touching each other. Values for such installations may be significantly lower and should be determined by an appropriate method.

Note 3: Values are given for vertical spacing between trays of 300 mm. For closer spacing, the factors should be reduced.

Note 4: Values are given to horizontal spacing between trays of 225 mm with trays mounted back to back. For closer spacing the factors should be reduced.

Note 5: For circuits having more than one core cable in parallel per phase, each three phase set of conductor should be considered as a circuit for the purpose of this table

Cables and Drums User Guide

1. Drums Handling

1.1. Position of Drums

Drums must be handled only in the upright position, not on the flanges.

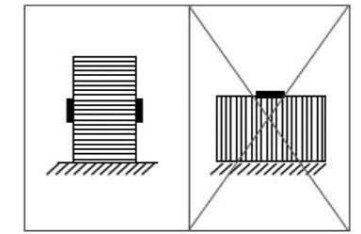

1.2. Loading:

Drums must be lifted only with mandrel or a chain through the central hole. It is important to use a spacing bar to leave a gap between the chain and the flanges of the drum. Do not lift more than one drum if its diameter is equal to or greater than 1,2 meters.

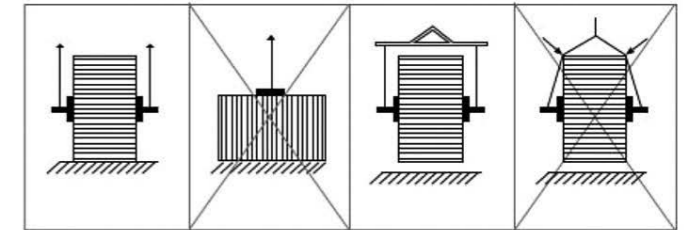

1.3. Unloading:

When unloading from vehicles (truck, ship, wagon etc.) the correct lifting gear must be used (forklift, truck, crane, etc.). Never drop drums, even from a small height.

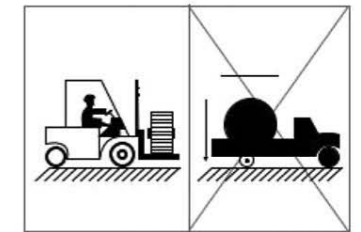

1.4. Handling by forklift:

If a forklift is used, always cradle both drum flanges between the forks. The forks must not bear on the unsupported laggings between flanges.

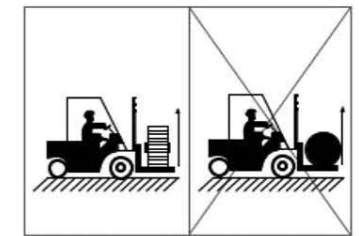

1.5. Rolling:

Drums are permitted to be rolled for short distances, the ground being smooth and free of injurious impediments, but only in the opposite direction of the arrow painted on flanges. If arrow sign is missed, drums may be rolled but only in the direction to cable winding, to keep cable from loosening the drum.

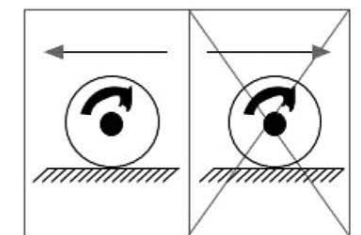

1.6. Paying-off the Cable:

When paying off a cable from a drum;

- 1) The lower end of the cable should be free.
- 2) Drums should be unreeled without exceeding the maximum allowed pulling force of the cable.
- 3) The minimum bending radius of the cable should be equal to or greater than 15x of the outer diameter of the cable.

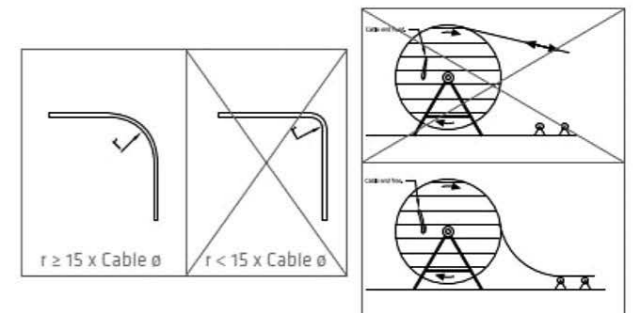

2. Transport Requirements

2.1. Position of the Drums:

Drums must be transported only in the upright position, not on the flanges. Never allow an unauthorized person to operate any lifting device or a mechanical transport.

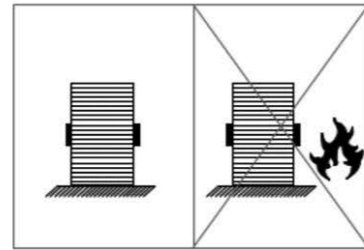

2.2. Fastening Drums:

Wedges must be used to retain drums. Wedges must be positioned at flanges' edges and not between flanges. The use of stones is forbidden. Where the load is unusual and is likely to need special care, ensure that all precautions are properly checked before the transport is allowed to move.

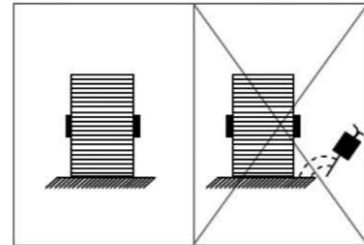

2.3. Use of Nails:

When nails are used to fasten drums on vehicles, be sure that the length of the nail is less than the thickness of the flange.

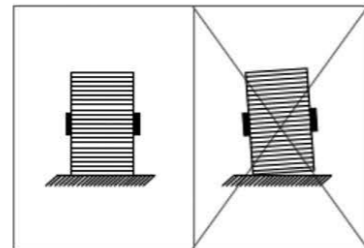

2.4. Bigger Drums:

Drums with diameter greater than 1.6 meters must be supported by wedges and must not touch the vehicle's floor. Never use a lifting device or transport device for a weight which exceeds its permitted capacity.

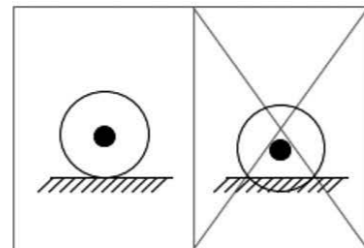

2.5. Binding of the Drums:

Binding must be made with ropes crossing through the central hole and, if necessary, on the drum flanges. Binding with ropes only crossing the drum's edges is strictly forbidden.

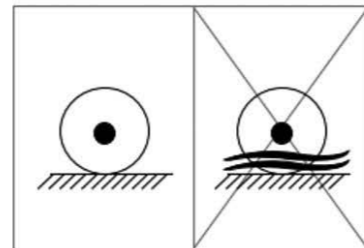

2.6. Multiple Drum Storage:

Multiple drum storage, either double or single layer must be obtained with flange to flange contact. Flanges contacting to unsupported part of lagings are forbidden.

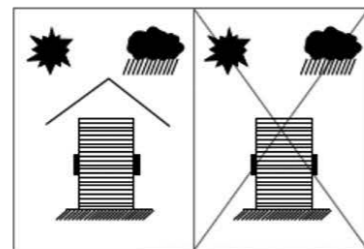

3. Storage Requirements

3.1.

Do not store near heat sources.

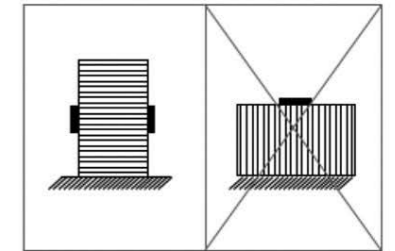

3.2.

Do not store on vibrating surfaces. (Ship engine room etc.) The bolts should be tightened monthly.

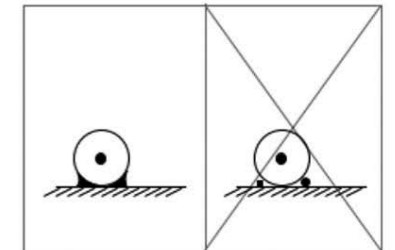

3.3.

Do not store on irregular surfaces. The drums should be rolled to an angle of 90° every three months.

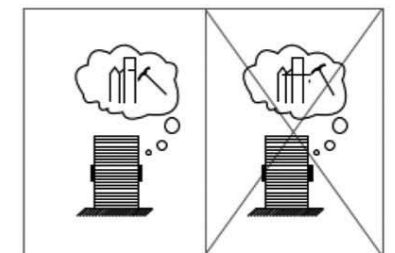

3.4.

Do not store on soft surfaces.

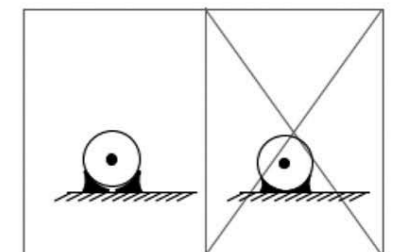

3.5.

Do not store on areas liable of flooding. All cable ends must be fully sealed at all times to prevent the ingress of water. It is preferable to store reels off the ground on timbers or other supports. In damp locations, it is advisable to allow at least 3 inches between reels to permit circulation of air.

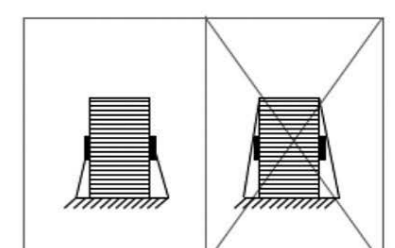

3.6.

In long term storages, drums should be stored in order to be protected from effects like rain, sunlight etc. If storage is more than 24 months, drums must be stored in an indoor area with A/C system.

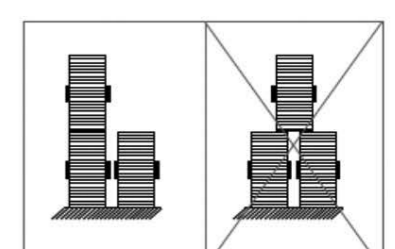

4. Suggestions for Cable Installation

4.1. Before Installation

In order to have a smooth and trouble-free installation, all necessary precautions should be taken before the installation. In case of a cable failure, cost of repairing/replacing the cable and the cost of power cut and energy losses will be very high. Therefore, these precautions will ensure that the cable is laid and the system will operate without any problem.

4.2. Direction of The Drum

The paying off should be performed in the opposite direction of the arrow that marked on the drum.

4.3. Cable Route

The cable route must be clean and free of burrs and sharp edges in order to prevent the damage on the cable outer sheath.

4.4. Installation Temperature

The recommended temperature for installation is +5°C. If the storage temperature is lower than the recommended temperature, the cable temperature should be adjusted to the suitable level before the installation.

4.5. Checks before the installation

Equipments that have an important function in cable pulling; such as cable grips, pulling eyes, drum mandrels etc. and the bolts on the drums must be checked before the installation.

4.6. After the installation

When only a portion of the cable is used, the open end of the cable remaining on the drum should immediately be re-sealed to prevent the entrance of moisture. Once it has been resealed, the cut end should be fixed to the inside edge of the drum flange to prevent the end from extending beyond the flanges during drum movement.

4.7. Outer Sheath

Excessive bending of the cable during installation may result in excessive pressure on the cable outer sheath. Therefore, the outer sheath pressure must be checked before reaching the level that can damage the cable.

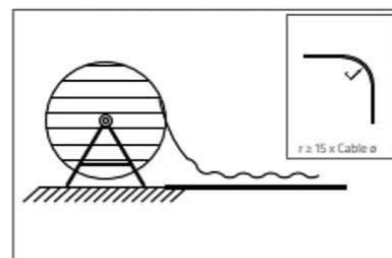
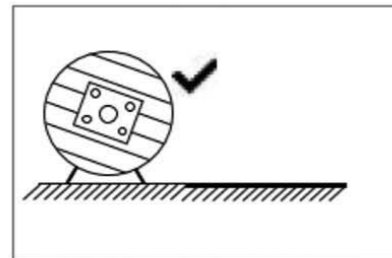
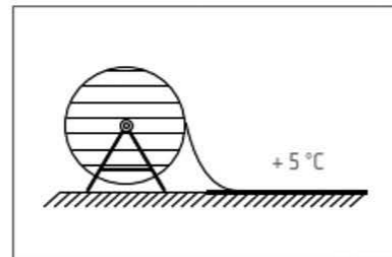
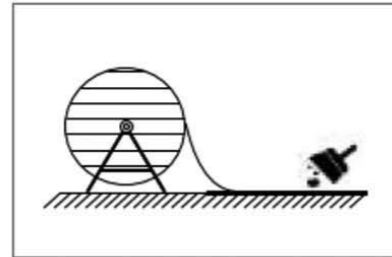
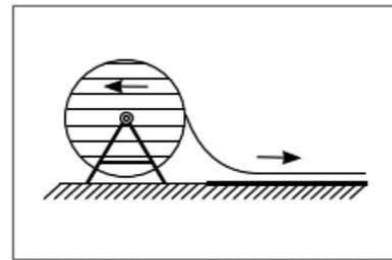
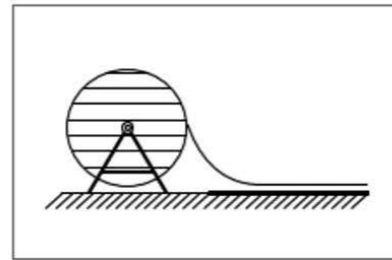

Sales & marketing offices

SINGAPORE

Prysmian APAC
Singapore Cables Manufacturers Pte Ltd
No 20 Jurong Port Road, Jurong Town
SINGAPORE 619094
Email: sales.asean@prysmian.com
Tel: +65 6265 0707 Fax +65 6265 2226

Prysmian PowerLink S.R.L.
Singapore Branch
(Submarine and EHV Systems)
No 20 Jurong Port Road, Jurong Town
SINGAPORE 619094
Email: sales.asean@prysmian.com
Tel: +65 6461 7800 Fax: +65 6898 3590

INDONESIA

PT Prysmian Cables Indonesia
Perkantoran Hljau Arkadia, Tower F, 7th Floor Suite 701
JI TB Simatupang Kav 88, Jakarta 12520
INDONESIA
Email: commercial.indonesia@prysmian.com
Tel: +62 21 781 6515 Fax +62 21 781 6504

MALAYSIA

Sindutch Cable Manufacturer Sdn Bhd
Suite 1201-3, Tower 2, Wisma Amfirst Jalan SS7/15 Off,
Jalan Stadium, SS 3, 47301 Petaling Jaya, Selangor
MALAYSIA
Email: scmm@prysmian.com
Tel +60 3 7803 7171 Fax: +60 3 7803 7575

THAILAND

MCI-Draka Cable Co Ltd
2170 Bangkok Tower, Phetchaburi Rd,
Bangkapi, Huai Khwang,
Bangkok 10310
THAILAND
Email: info.th@prysmian.com
Tel: +662 3080 830 Fax: +662 6080 054

VIETNAM

Singapore Cables Manufacturers Pte Ltd
Vietnam Rep Office
Unit 1605, 16th Floor, Havana Tower
132 Ham Nghi Street, Dist 1, HCMC 70000
VIETNAM
Email: sales.asean@prysmian.com
Tel: + 84 28 392 60581 Fax: +84 28 392 60580

Manufacturing plants

SINGAPORE

Singapore Cables Manufacturers Pte Ltd
(Warehouse)
No 20 Jurong Port Road, Jurong Town
SINGAPORE 619094
Email: sales.asean@prysmian.com
Tel: +65 6265 0707 Fax +65 6265 2226

INDONESIA

PT Prysmian Cables Indonesia
Kawasan Industri Indotaisei, Blok G-1,
Kota Bukit Indah, Cikampek 41373,
Jawa Barat, INDONESIA
Email: commercial.indonesia@prysmian.com
Tel: +62 264 351 222 Fax: +62 264 351 778

MALAYSIA

Sindutch Cable Manufacturer Sdn Bhd
Lot 38, Jalan Industri 11,
Alor Gajah Industrial Estate
78000 Alor Gajah, Melaka
MALAYSIA
Email: scmm@prysmian.com
Tel: +60 6 5563 833 Fax: +60 6 5563 282

THAILAND

Rayong Factory
2/7 Ban-bueng Bankhai Road KM 57,
Nongbua Moo 2, Ban Khai, Rayong 21120
THAILAND
Email: info.th@prysmian.com
Tel: +66 38 961 158 Fax: +66 38 961 167

Certification Partners





www.prysmian.com

Follow us

